



SUZUKI
MARINE

Parts Book
DT 3.5 (79)

PREFACE

This parts catalogue has been arranged to include all prior modification as the final edition.
 No revised edition will be issued any more and be sure to make use of this in good keeping.
 Upon receipt of this final edition, the old catalogue should be thrown away.
 This parts catalogue covers the list of all service parts for SUZUKI DT2~DT9 (C, D, F).

A. INSTRUCTIONS FOR QUOTING THE CATALOGUE

1. DIMENSIONS

Dimensions of the parts in this catalogue are indicated in unit millimeters.

2. ABBREVIATIONS

Abbreviations used in this catalogue are as follows:

AR : As required	NT : Number of teeth
ASSY : Assembly	OPT : Optional
E.No. : Engine Number	OS : Over Size
F.No. : Frame Number	STD : Standard
d : Diameter of material	T : Thickness
ID : Inside diameter	US : Under size
OD : Outside diameter	W : Width
L : Length	S,L,UL,LL : Transom type
LH : Left hand side	
RH : Right hand side	
~100045 : Up to F.No.-100045	
100046~ : From F.No.-100046	

12 x 34 x 5.6Figures in the description column show the dimensions of parts.
 | | |
 ID OD T(or W,L)

To 12340-56781 (Parts No.) : indicates that the parts number was changed to 12345-56781 and the new parts are interchangeable with the former ones but the former ones are not interchangeable with new ones.

From 12345-56781 (Parts No.) : indicates that the former and new parts are interchangeable with each other and both are usable.

The number of letter shown below Q'ty indicate the MODEL NAME as shown right side.

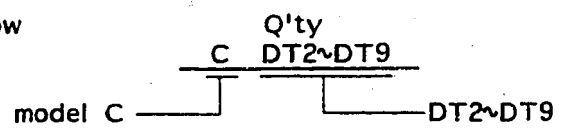

3. INNER PARTS OF ASSEMBLY

Parts number that have a period (.) mark in front of the part description on a text page are separately serviced parts of the assembly.

4. MODIFICATION NOTICE

A parts bulletin will be sent to you on all occasions when changes in parts occur, including interchangeable modifications between new parts and old ones.

5. NOTE

5-1. There are some different parts from those of production models among spare parts for the administrative reasons and common use of them with other models.

5-2. In respect of rubber hoses and vinyl tubes, please be sure to use them by cutting off according to the length mentioned on parts catalogue or what is actually required on the vehicle.

5-3. Note that the drawings on the illustration page are for ready reference of spare parts number, not to be used as an assembly manual.
 When assembling, use "SUZUKI SERVICE MANUAL".

6. SPECIFICATION CODE

This catalogue contains the parts for the model designed for the following spec. ;
 spec. code: DT2C (E1, E28), DT2D (E1), DT2F (E1), DT3.5F (E1, E16), DT4.5C (E1, E28), DT4D (E1), DT5D (E1, E3, E13), DT5F (E1, E3, E13), DT7.5C (E1, E13, E28), DT7.5D (E1, E13), DT7.5F (E1, E9, E13), DT9C (E1, E13, E28, E37), DT9D (E1, E13), DT9F (E1, E9, E13)

7. SERIAL FRAME NUMBER

C-10001~, D-10001~, F-10001~

FIG. 13

C - 3

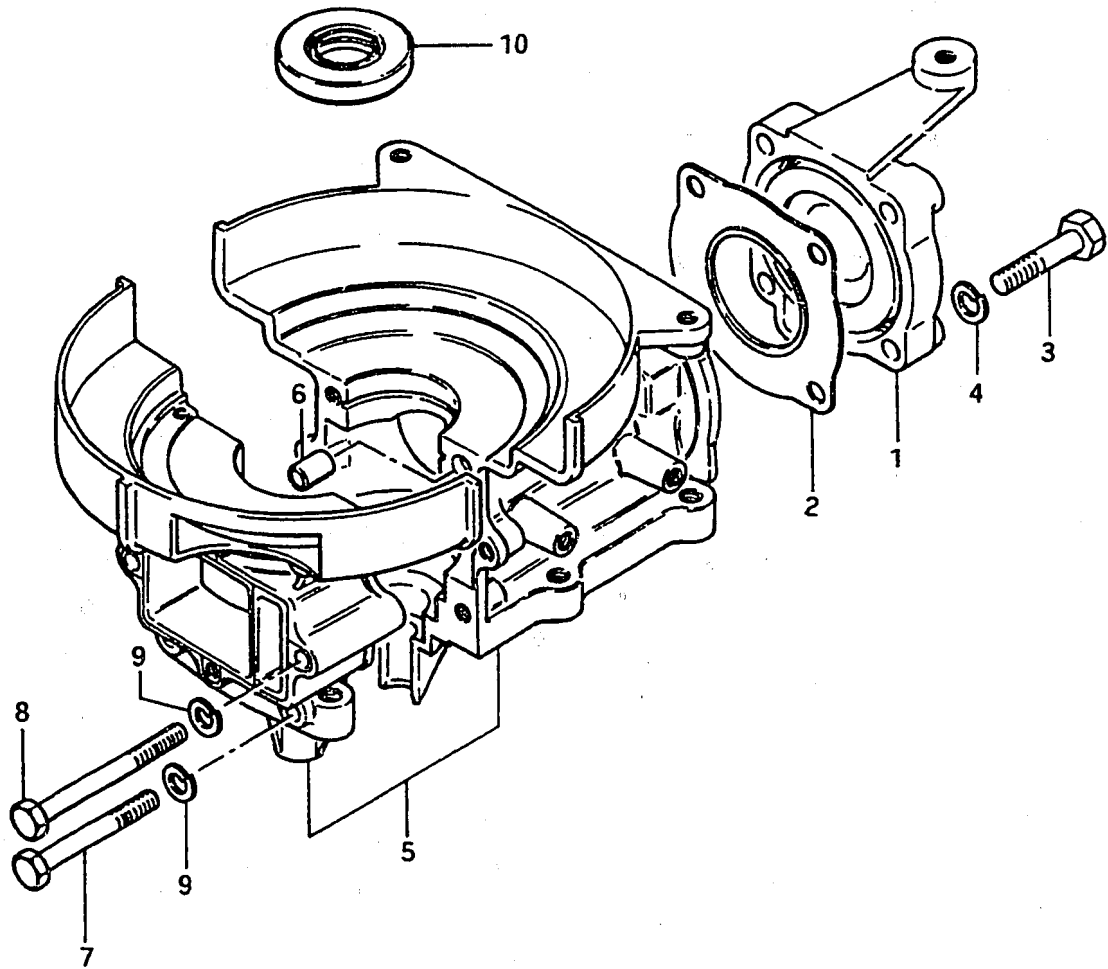

FIG. 13 CYLINDER

Ref. No.	Part No.	Description	Q'ty	Remarks
1	11111-98300-01J	CYLINDER HEAD	1	
2	11141-98300	GASKET, cylinder head	1	
3	01107-08408	BOLT, cylinder head	4	
4	08321-21088	LOCK WASHER	4	
5-1	11300-98860-01J	CYLINDER SET	1	to 11300-98861-01J
5-2	11300-98861-01J	CYLINDER SET	1	
5-3	11300-98862-01J	CYLINDER SET	1	to 11300-98863-01J
5-4	11300-98300-01J	CYLINDER SET	1	from 11300-98863-01J
6	04211-09109	·DOWEL PIN	2	
7	01107-06558	·BOLT 1	4	
8	01107-06758	·BOLT 2	2	
9	08321-21068	·LOCK WASHER	6	
10	09283-20016	OIL SEAL	1	20x47x8

FIG. 14

C - 4

FIG. 14 CRANKSHAFT

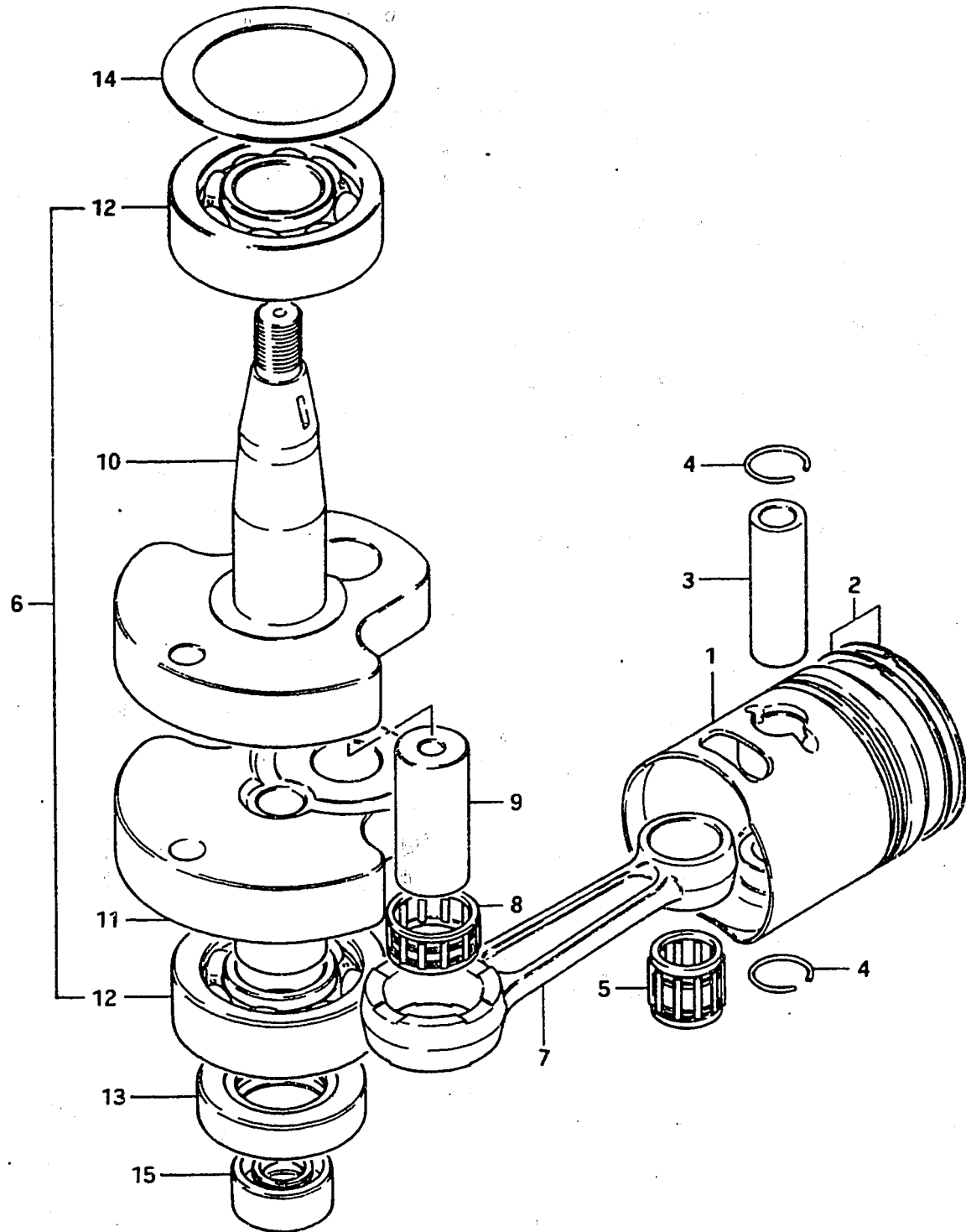

Ref. No.	Part No.	Description	Q'ty	F	Remarks
1-1	12110-98006	PISTON	1		
1-2	12110-98006-025	PISTON	1		OS:0.25 OPT
1-3	12110-98006-050	PISTON	1		OS:0.5 OPT
2-1	12140-98013	RING SET, piston	1		
2-2	12140-98013-025	RING SET, piston	1		OS:0.25 OPT
2-3	12140-19610-050	RING SET, piston	1		OS:0.5 OPT
3	12151-09204	PIN, piston	1		
4	09381-12001	CIRCLIP, piston pin	2		
5	09263-12003	BEARING, piston pin	1		12x16x15.8
6-1	12200-98850	CRANKSHAFT ASSY	1		
6-2	12200-98301	CRANKSHAFT ASSY	1		from 12200-98850
7	12161-35000	•ROD, connecting	1		
8-1	09263-16014	•BEARING, crank pin	1		16x22x11.85 to 09263-16016
8-2	09263-16016	•BEARING, crank pin	1		
9	12211-98300	•PIN, crank	1		
10	12221-98300	•CRANKSHAFT, upper	1		
11	12240-98300	•CRANKSHAFT, lower	1		
12	08113-62040	•BEARING	2		
13	09283-20018	OIL SEAL, lower crankshaft	1		20x37x9
14	09160-38001	THRUST WASHER	1		38x51x1
15-1	09283-10001	OIL SEAL, upper drive shaft	1		10x22x8 to 09283-10003
15-2	09283-10003	OIL SEAL, upper drive shaft	1		10x22x8

FIG. 15

C - 5

FIG. 15 REED VALVE

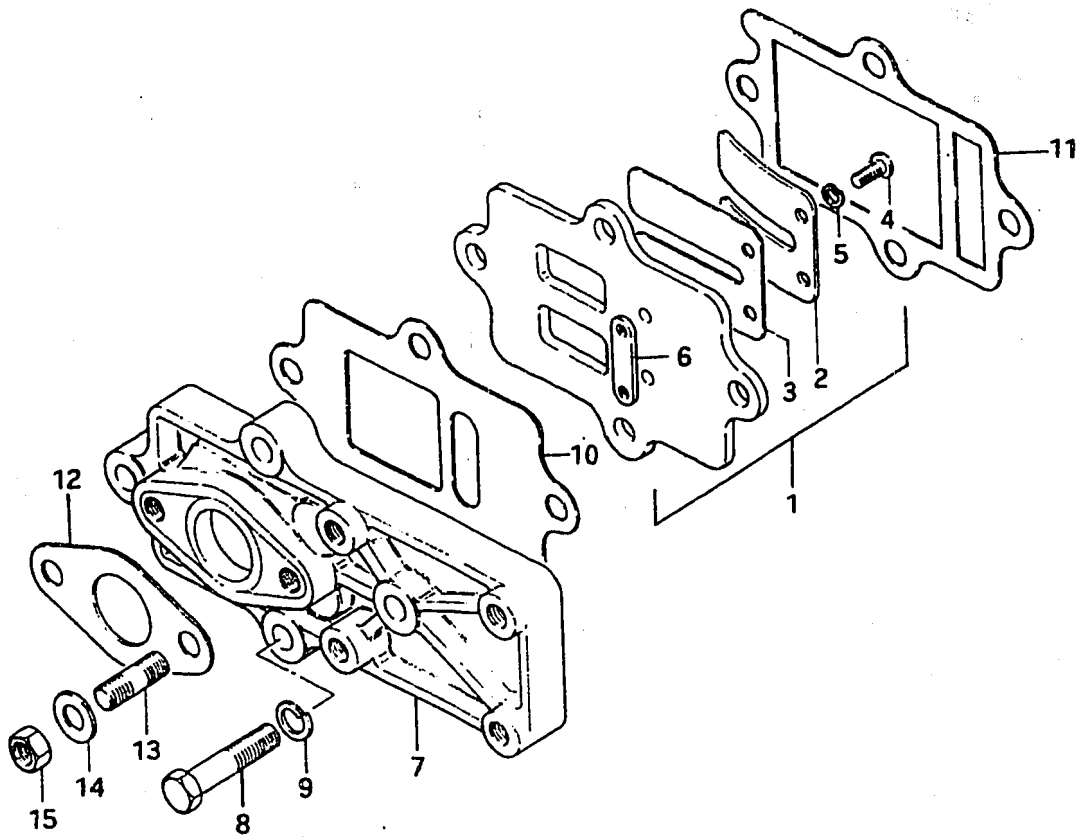

Ref. No.	Part No.	Description	Q'ty	Remarks
1	13150-98300	VALVE ASSY, reed	1	
2	13152-98300	•STOPPER, reed valve	1	
3	13153-98300	•VALVE, reed	1	
4	02112-03088	•SCREW	2	
5	08321-21038	•LOCK WASHER	2	
6	13154-98300	•PLATE, reed valve	1	
7	12481-98300-01J	CASE, inlet	1	
8	01107-06308	BOLT	2	
9	08321-21068	LOCK WASHER	2	
10	13121-98300	GASKET, inlet case	1	
11	13122-98300	GASKET, valve seat	1	
12	13125-98300	GASKET, carburetor	1	
13	01421-06168	STUD BOLT	2	
14	08322-21068	WASHER	2	
15	08310-11068	NUT	2	

FIG.16

C - 6

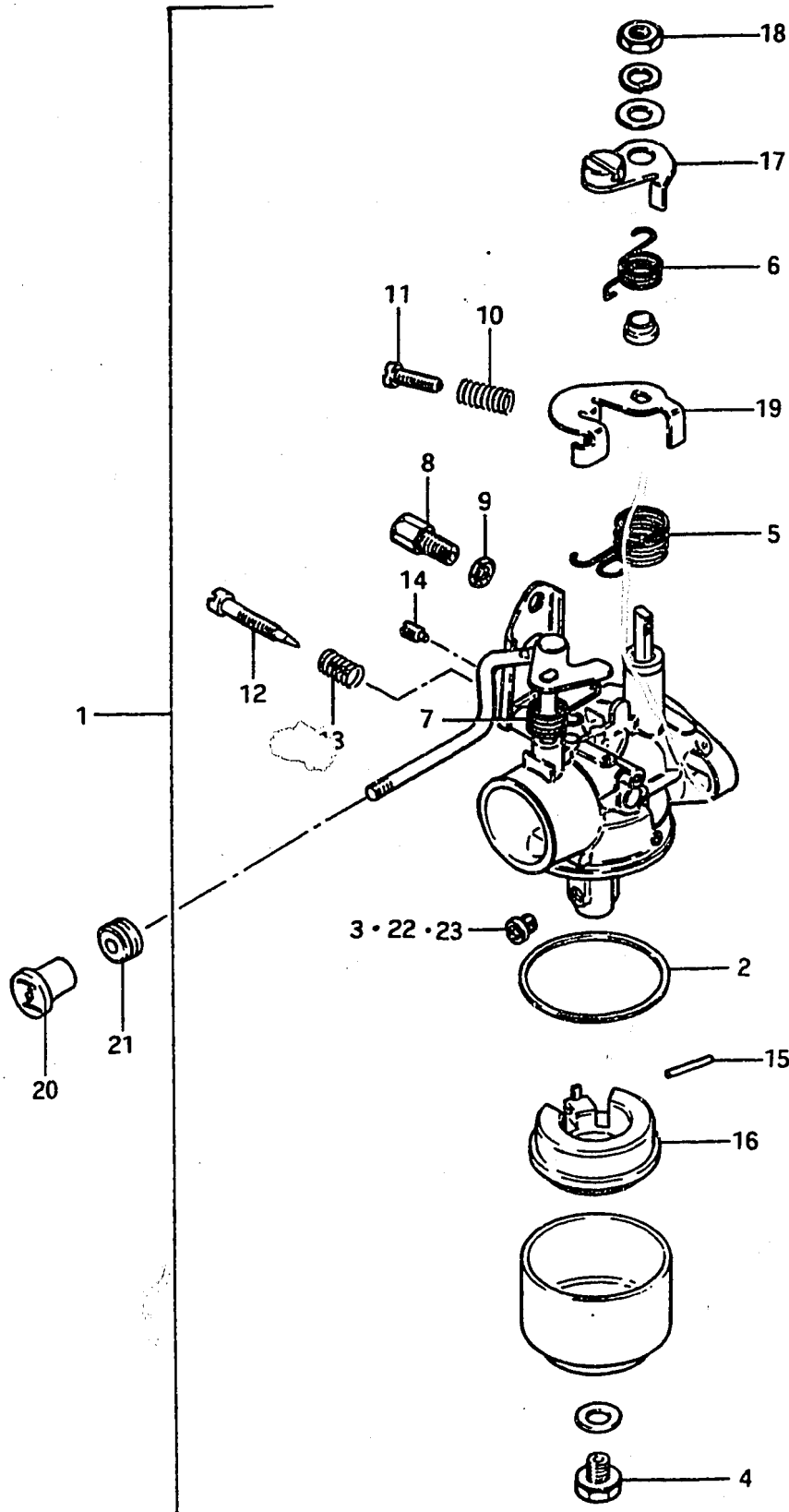

FIG.16 CARBURETOR

Ref. No.	Part No.	Description	Q'ty	Remarks
			F	
1-1	13200-98300	CARBURETOR ASSY	1	stamp:98300 to 13200-98301
1-2	13200-98301	CARBURETOR ASSY	1	stamp:98301 to 13200-98302
1-3	13200-98302	CARBURETOR ASSY	1	stamp:98302 to 13200-98303
2	13251-98300	•GASKET, float chamber	1	
3	09491-90001	•JET, main	1	90
4	13613-98300	•BOLT	1	
5	13573-98320	•SPRING	1	
6	13573-98310	•SPRING	1	
7	13592-98300	•SPRING	1	
8-1	13577-03010	•ADJUSTER, throttle cable	1	
8-2	13577-48110	•ADJUSTER, throttle cable	1	from 13577-03010
9	13661-03010	•NUT, adjuster	1	
10	13268-92910	•SPRING	1	
11	13267-98300	•SCREW, throttle stop	1	
12	13269-98300	•SCREW, pilot air	1	
13	13268-96110	•SPRING	1	
14	09493-32004	•JET, air	1	
15	13254-98300	•PIN	1	
16	13250-98300	•FLOAT	1	
17	13553-98300	•LEVER, starter	1	
18	13607-98300	•NUT	1	
19	13564-98300	•LEVER, throttle	1	
20-1	13631-99002	KNOB, starter	1	to 13631-93500
20-2	13631-93500	KNOB, starter	1	
21	09305-04003	BUSHING, starter knob	1	
22	09491-85001	JET, main	1	OPT,85
23	09491-95001	JET, main	1	OPT,95

FIG. 17

C - 7

5

FIG. 17 FUEL PUMP

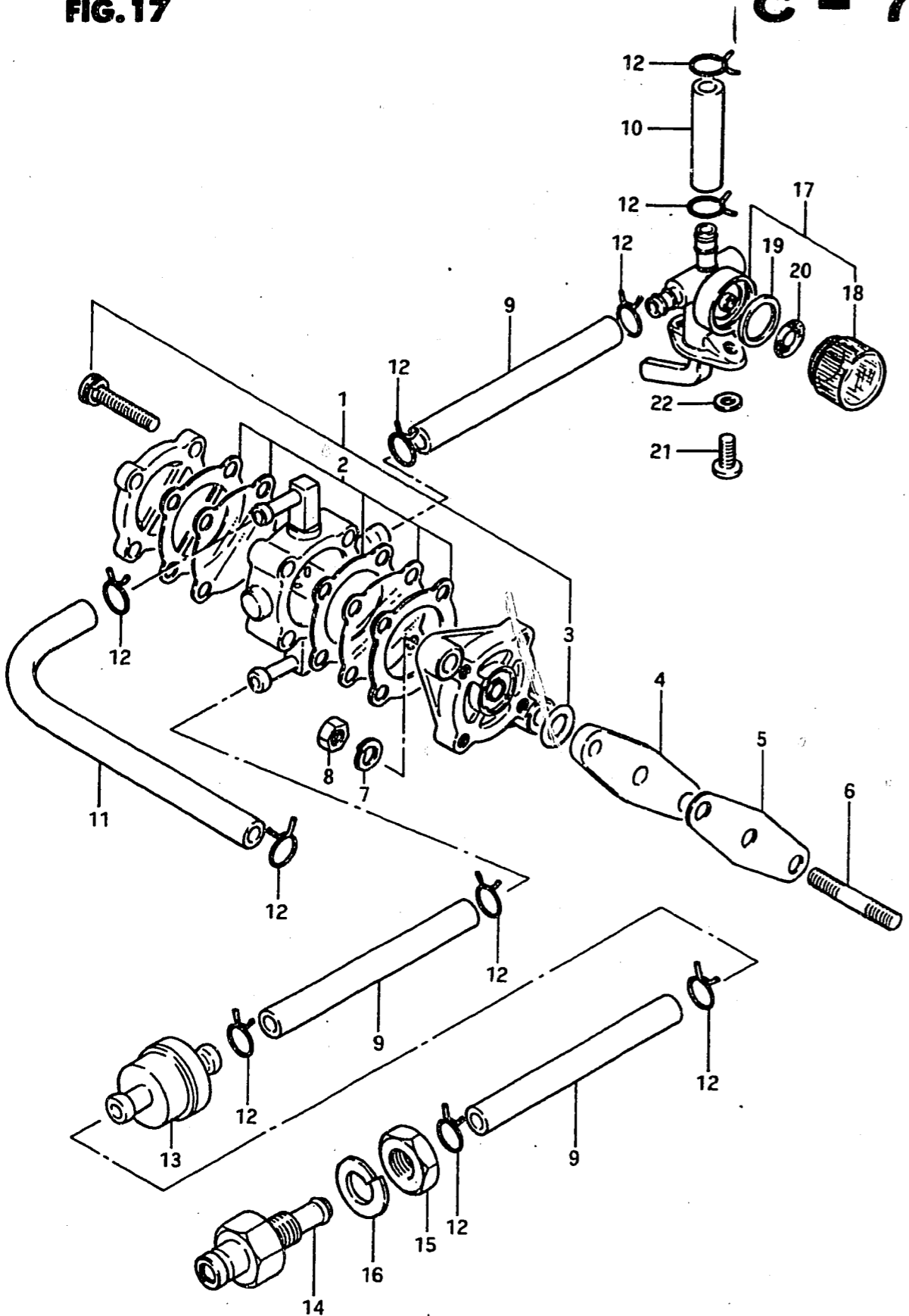

Ref. No.	Part No.	Description	Q'ty	Remarks
1-1	15100-98300	PUMP ASSY, fuel	1	to 15100-98320
1-2	15100-98320	PUMP ASSY, fuel	1	to 15100-98321
1-3	15100-98321	PUMP ASSY, fuel	1	
2	15180-98811	•VALVE SET	1	
3	15165-93010	•O RING, fuel pump	1	
4	15322-98500	INSULATOR, fuel pump	1	
5	15321-98500	GASKET, fuel pump	1	
6	09108-05006	STUD BOLT	2	
7	08321-21058	LOCK WASHER	2	
8	08310-11058	NUT	2	
9	09343-05137	HOSE, fuel	3	L:500*85
10	09343-05137	HOSE, fuel (tank to cock)	1	L:500*36
11	09343-05137	HOSE, fuel (pump to carburetor)	1	L:500*165
12	09401-09402	CLIP, fuel hose	10	from 09401-08403
13	15410-98500	FILTER, fuel	1	
14-1	65720-98500	PLUG, fuel connector	1	to 65720-98501
14-2	65720-98501	PLUG, fuel connector	1	to 65720-98502
14-3	65720-98502	PLUG, fuel connector	1	to 65720-98520
14-4	65720-98520	PLUG, fuel connector	1	
15	08310-22108	NUT	1	
16	08321-21108	LOCK WASHER	1	
17-1	66100-98300	COCK ASSY, fuel	1	to 66100-98301
17-2	66100-98301	COCK ASSY, fuel	1	
18	66171-98300	•CUP, filter	1	
19	66273-98300	•GASKET, filter	1	
20	66152-98300	•NET, filter	1	
21	02112-04128	SCREW	2	
22	08322-21048	WASHER	2	

FIG.18

C - 8

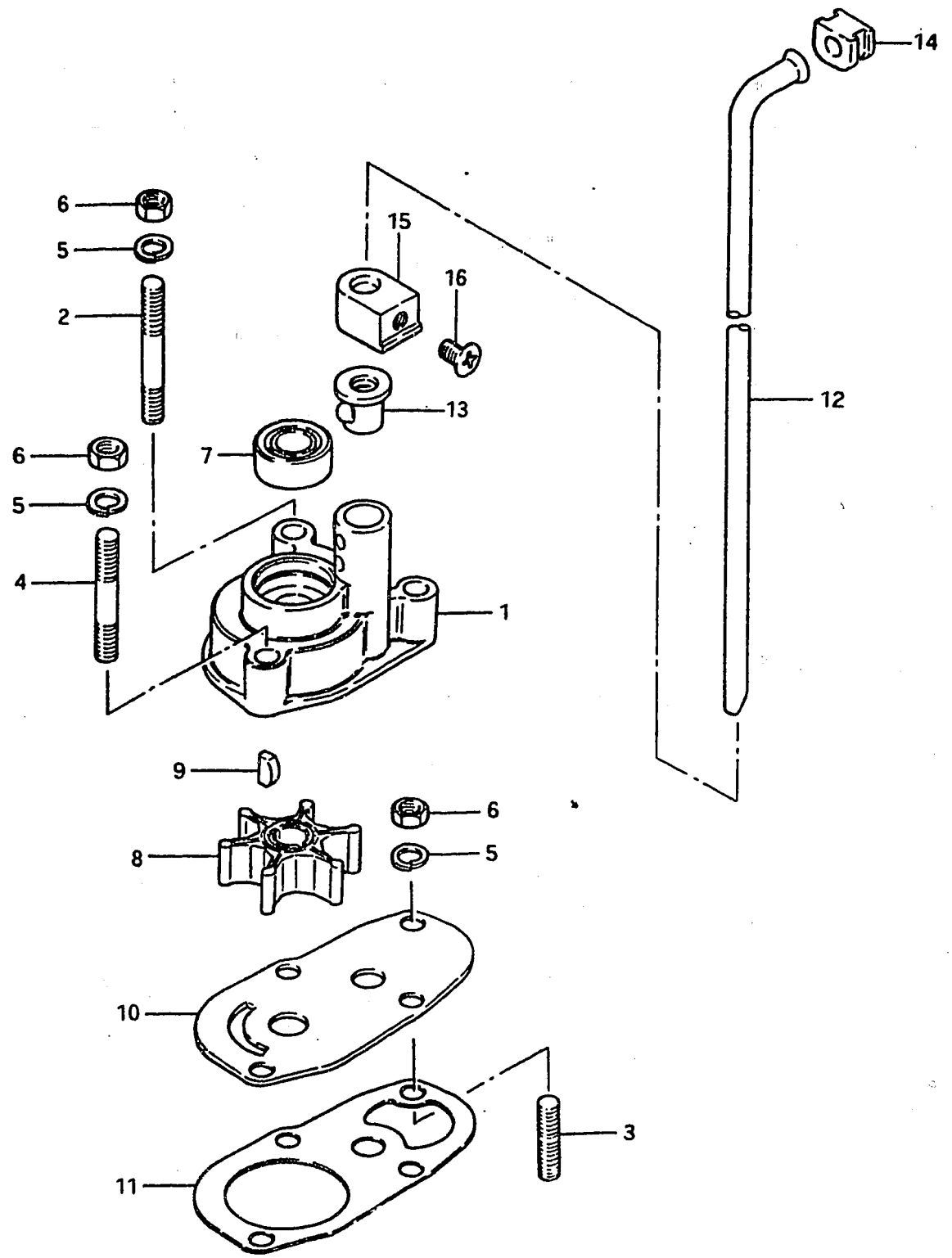

FIG.18 WATER PUMP

Ref. No.	Part No.	Description	Q'ty	Remarks
1	17411-98300	CASE, water pump	1	
2	09108-06005	STUD BOLT, pump case	1	
3	09108-06022	STUD BOLT, pump case	1	
4	09108-06025	STUD BOLT, pump case	2	
5	09162-06001	LOCK WASHER	4	
6	09140-06004	NUT	4	
7	09289-10002	OIL SEAL, pump case	1	10x22x8
8-1	17461-98401	IMPELLER, water pump	1	to 17461-98402
8-2	17461-98402	IMPELLER, water pump	1	
9	09420-03002	KEY	1	
10-1	17471-98300	PANEL, lower pump	1	to 17471-98301
10-2	17471-98301	PANEL, pump panel	1	
11	17472-98300	GASKET, pump panel	1	
12-1	17561-98310	TUBE, water	1	S type
12-2	17561-98320	TUBE, water	1	L type
13	17415-98500	BUSHING, water pump	1	
14	09309-06005	GROMMET, water pump	1	
15	17564-98300	GUIDE, water tube	1	
16	09126-05003	SCREW, water tube guide	1	5x12

FIG.19

C - 9

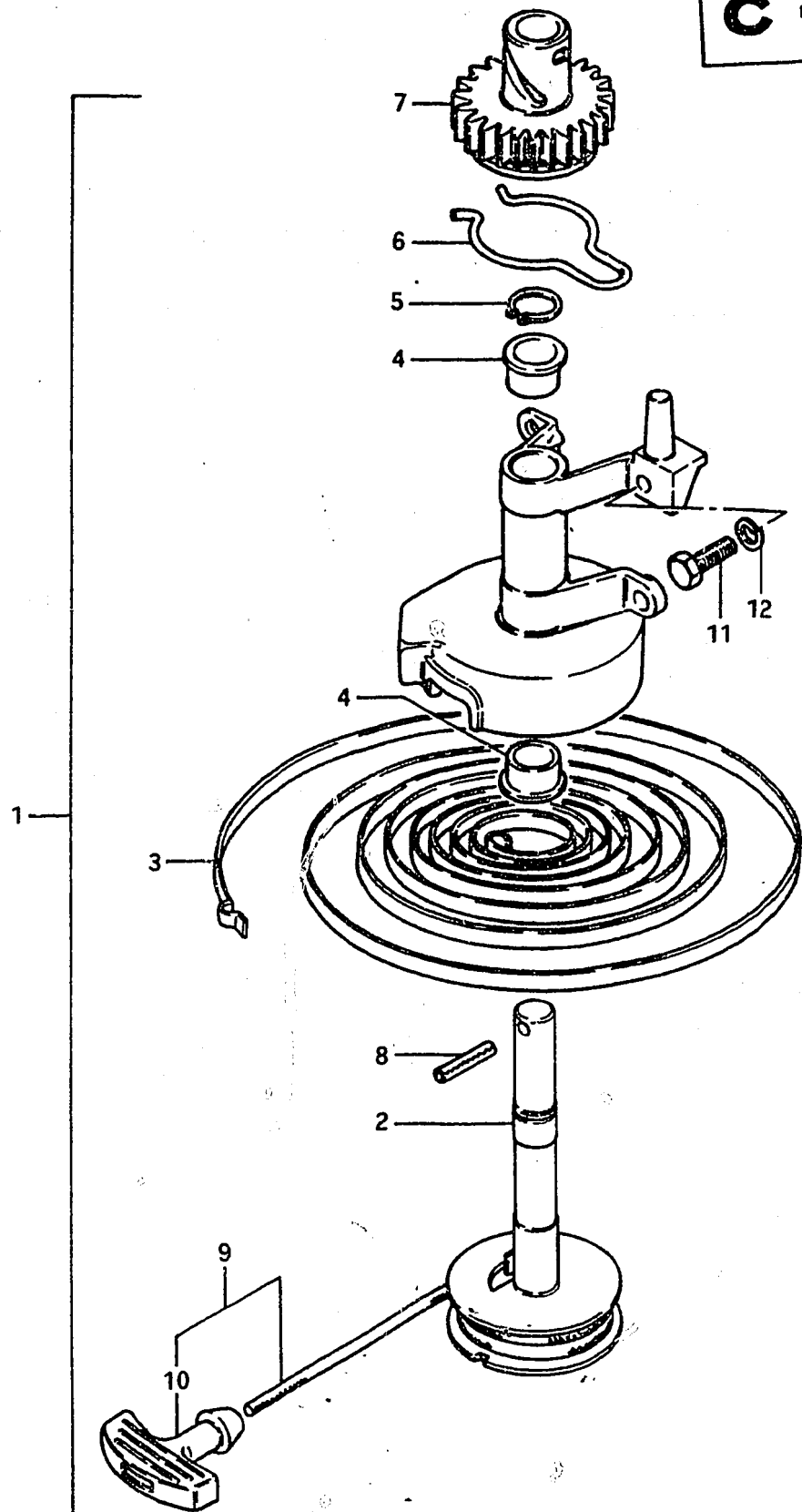

FIG.19 RECOIL STARTER

Ref. No.	Part No.	Description	Q'ty	Remarks
1-1	18100-98300-291	STARTER ASSY, recoil	1	to 18100-98301-291
1-2	18100-98301-291	STARTER ASSY, recoil	1	
2	18121-98300	•REEL, starter	1	
3	18142-98300	•SPRING, recoil	1	
4-1	18522-98300	•BUSHING, starter	2	
4-2	18253-98300	•BUSHING, starter	2	from 18522-98300
5-1	18524-98300	•CIRCLIP, starter	1	to 18524-98301
5-2	18255-98301	•CIRCLIP, starter	1	from 18524-98301
6-1	18541-98300	•SPRING, friction	1	
6-2	18271-98300	•SPRING, friction	1	from 18541-98300
7-1	18531-98300	•PINION, starter	1	
7-2	18261-98300	•PINION, starter	1	from 18531-98300
8-1	18525-98300	•PIN, starter	1	
8-2	18344-98301	•PIN, starter	1	from 18525-98300
9-1	18170-98300	•GRIP ASSY, starter	1	to 18170-98301
9-2	18200-98301	•GRIP ASSY, starter	1	from 18170-98301
10	18210-98400	•GRIP	1	
11	01107-06208	BOLT	4	
12	08321-21068	LOCK WASHER	4	

FIG. 20

C - 10

FIG. 20 MAGNETO

Ref. No.	Part No.	Description	Q'ty	Remarks
1	32100-98300	MAGNETO ASSY	1	
2	32102-98310	•ROTOR ASSY	1	from 32102-98300
3	32101-98301	•STATOR ASSY	1	from 32101-98300
4	32140-98300	••COIL, ignition	1	
5	08321-21058	••LOCK WASHER	2	
6	02112-05258	••SCREW	2	
7	32240-98034	••POINT ASSY, contact	1	
8	02311-04108	••SCREW	1	
9	08322-21048	••WASHER	1	
10	08321-21048	••LOCK WASHER	1	
11	32341-98030	••CONDENSER	1	
12	08321-21038	••LOCK WASHER	1	
13	02112-03088	••SCREW	1	
14	02112-05128	SCREW, stator	2	
15	08322-21058	WASHER	2	
16	08310-12108	NUT, flywheel	1	
17	08321-31108	LOCK WASHER	1	
18	08341-31039	KEY	1	
19	18411-98300	CUP, starter	1	
20	01107-06128	BOLT	3	
21	08321-21068	LOCK WASHER	3	

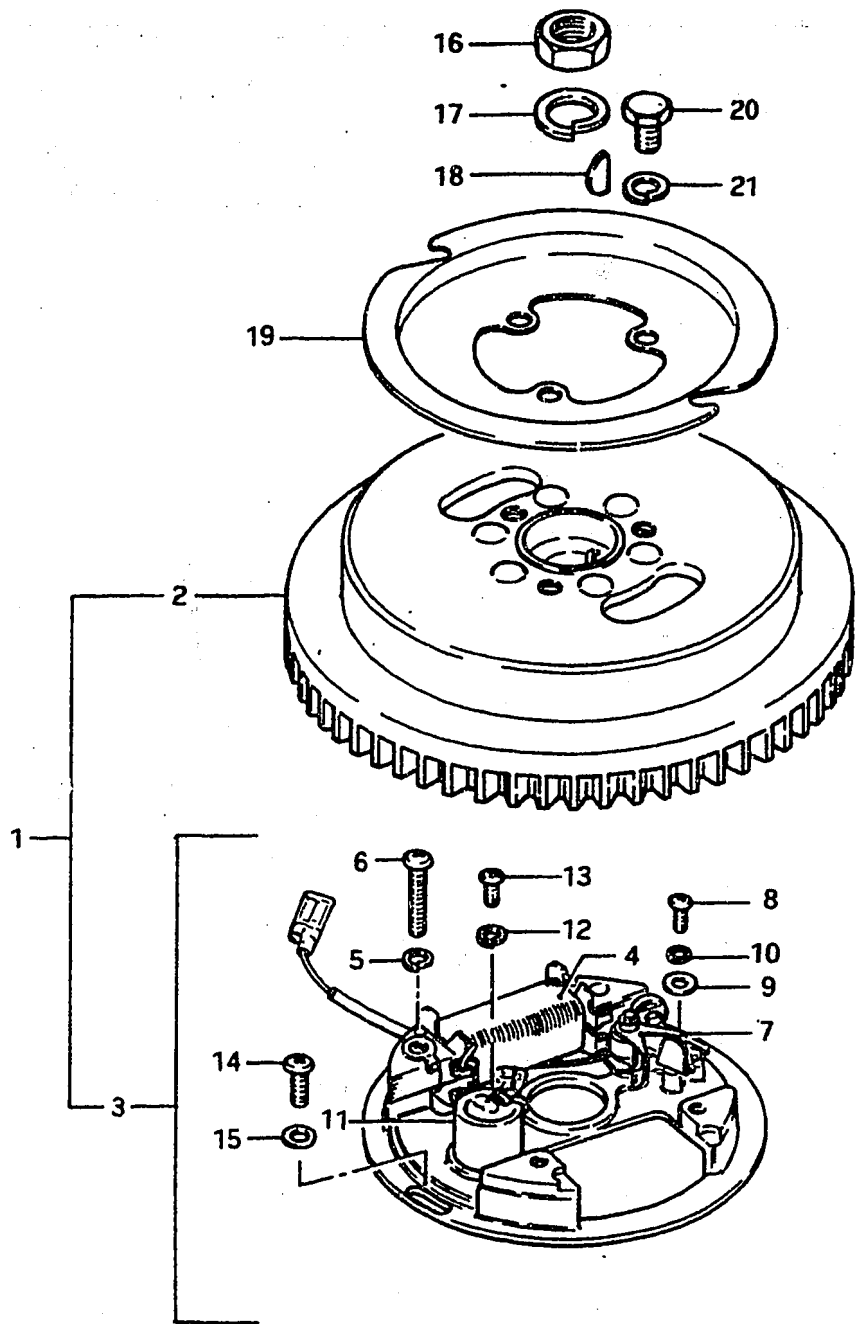

FIG.21

C - 11

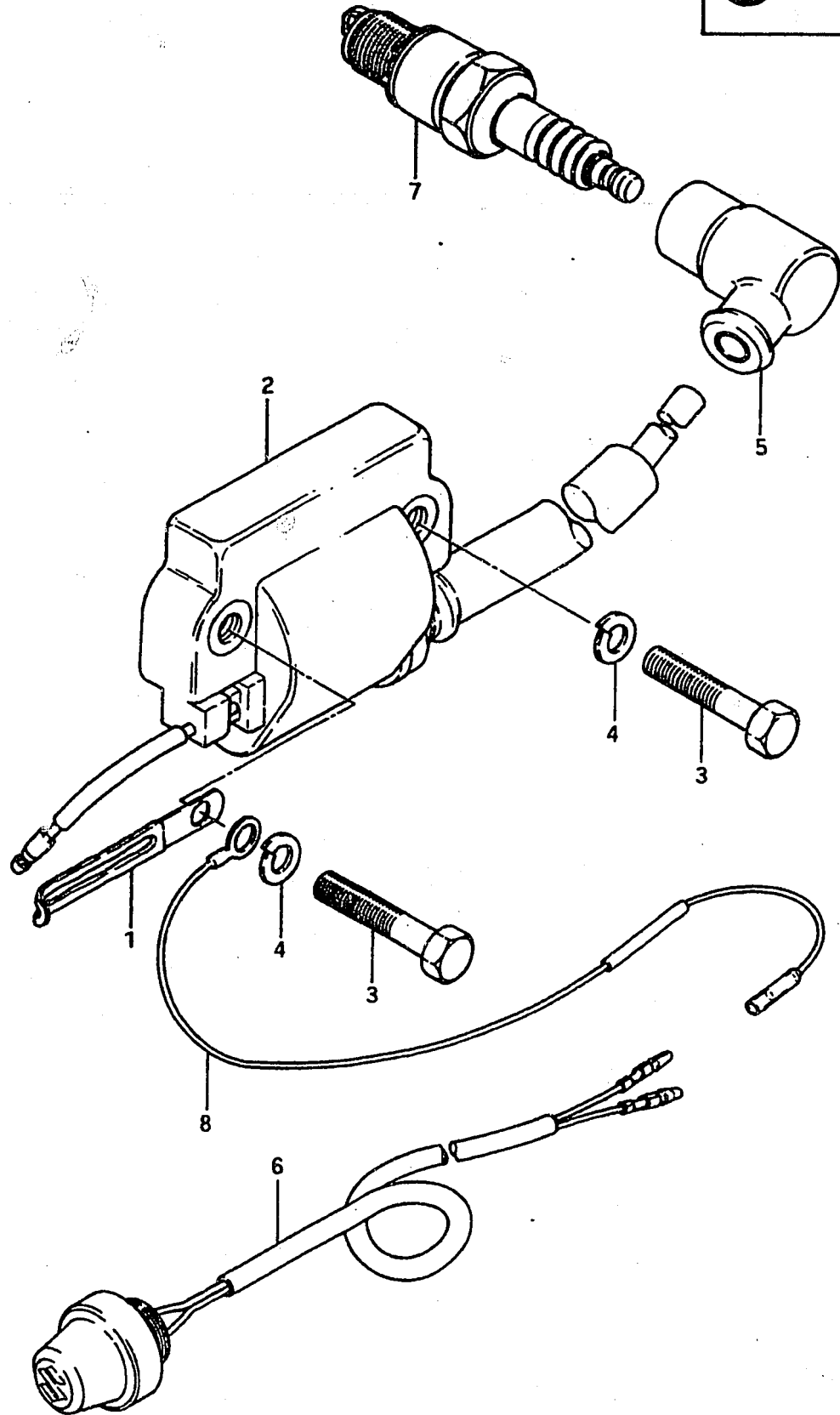

FIG.21 ELECTRICAL

Ref. No.	Part No.	Description	Q'ty	F	Remarks
1-1	09404-06402	CLAMP, magneto lead wire	1		to 09404-06412
1-2	09404-06412	CLAMP, magneto lead wire	1		
2	33410-98300	COIL ASSY, ignition	1		
3	01107-06308	BOLT	2		
4	08321-21068	LOCK WASHER	2		
5	33510-95510	CAP, spark plug	1		
6-1	37870-93113	SWITCH ASSY, stop	1		
6-2	37800-93150	SWITCH ASSY, stop	1		from 37870-93113
7	09482-00141	SPARK PLUG	1		BPR6HS, NGK
8-1	37801-98350	LEAD, stop switch	1		
8-2	37801-98351	LEAD, stop switch	1		from 37801-98350

FIG.22

C - 12

10

FIG.22 CLUTCH

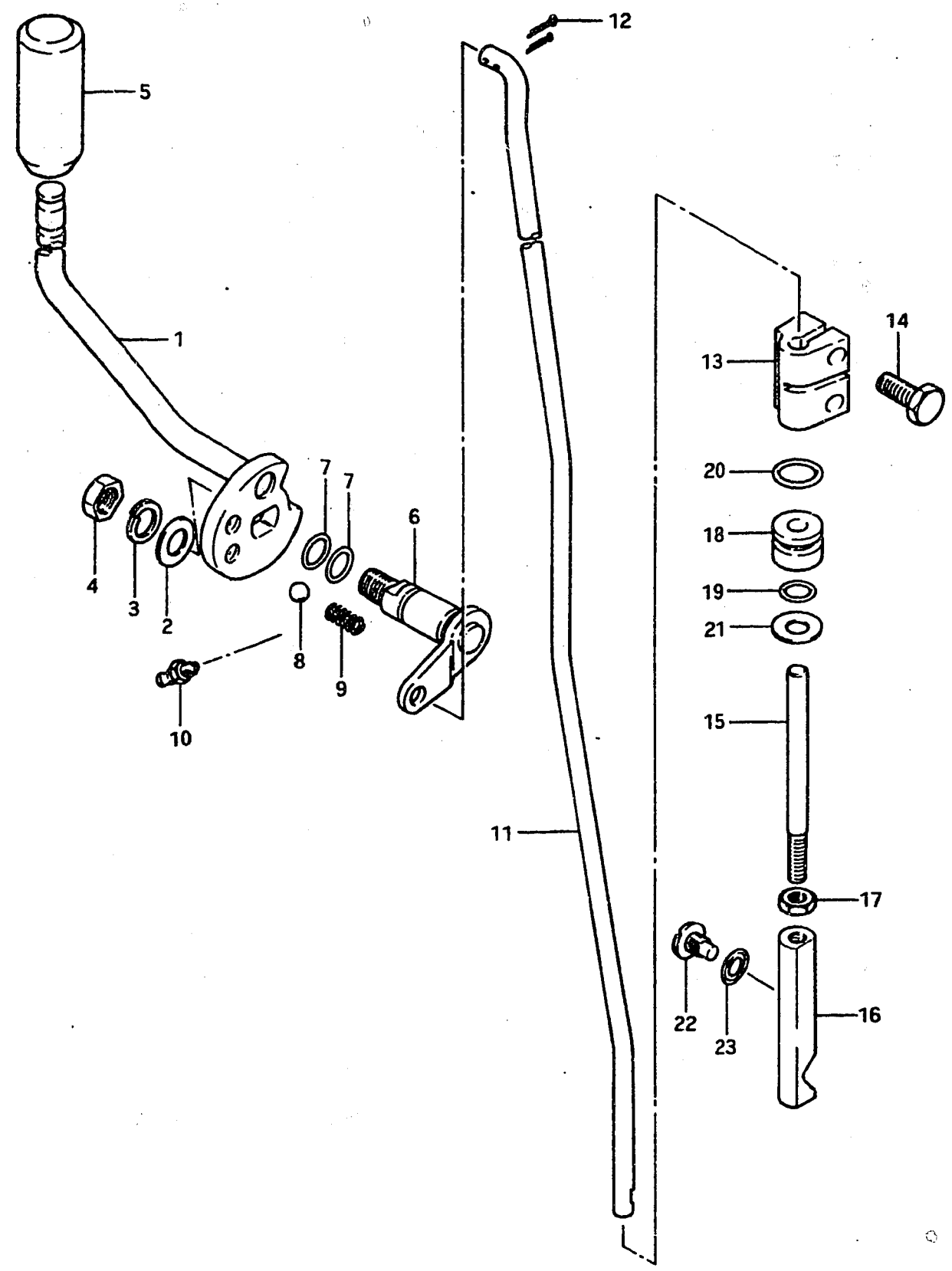

Ref. No.	Part No.	Description	Q'ty	Remarks
1-1	21110-98300	LEVER, clutch	1	to 21110-98302
1-2	21110-98302	LEVER, clutch	1	
2	09160-08015	WASHER, clutch lever	1	8.5x16x1.6
3	09162-08003	LOCK WASHER	1	
4	09140-08003	NUT	1	
5	21141-98500	KNOB, clutch lever	1	
6-1	21210-98300	SHAFT, clutch lever	1	
6-2	21210-98301	SHAFT, clutch lever	1	from 21210-98300
7	09280-09003	O RING, clutch lever shaft	2	
8	09260-10003	BALL, clutch notch	1	
9	09440-07021	SPRING, clutch notch	1	
10	22511-99000	GREASE NIPPLE, clutch	1	
11-1	23111-98310	ROD, clutch	1	S type,L:458
11-2	23111-98320	ROD, clutch	1	L type,L:585
12	09204-01001	COTTER PIN	2	
13	23311-93001	CONNECTOR, clutch rod	1	
14	09100-06019	BOLT, clutch rod	2	6x16
15	25111-98300	ROD, shifting	1	
16	25311-98300	CAM, shifting	1	
17	08310-11058	NUT	1	
18	25211-99004	GUIDE, shifting rod	1	
19	09280-06004	O RING, shifting rod	1	
20	09280-11001	O RING, shifting rod guide	1	
21	08212-06151	WASHER	1	
22	09139-06003	SCREW, shifting cam stop	1	
23	09168-06002	GASKET, cam stop screw	1	

FIG. 23

C - 13

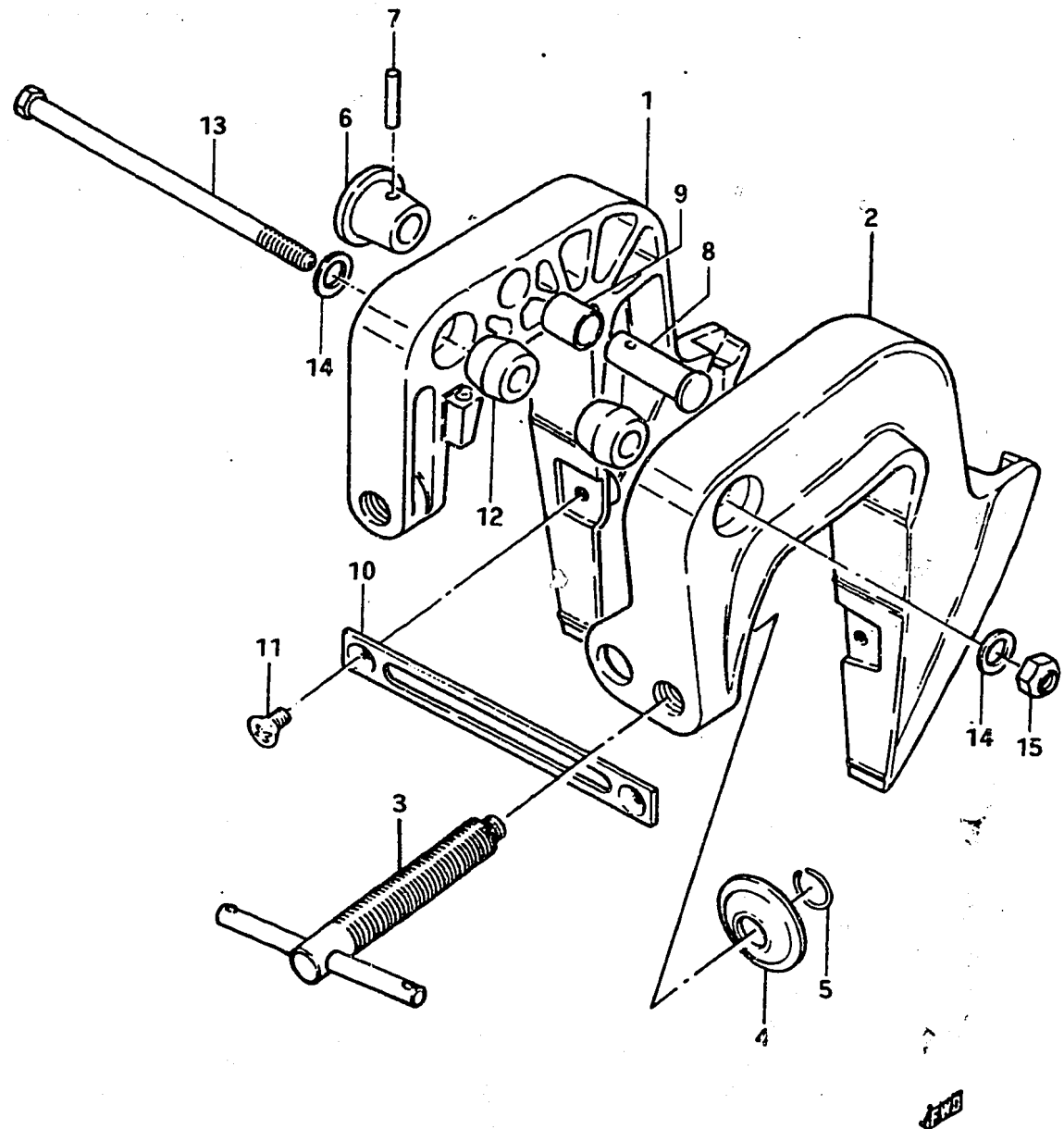

FIG. 23 CLAMP BRACKET

Ref. No.	Part No.	Description	Q'ty	Remarks
1-1	41111-98501-01J	BRACKET, clamp RH	1	to 41111-98502-01J
1-2	41111-98502-01J	BRACKET, clamp RH	1	to 41111-98503-01J
1-3	41111-98503-01J	BRACKET, clamp RH	1	
2-1	41121-98500-01J	BRACKET, clamp LH	1	to 41121-98501-01J
2-2	41121-98501-01J	BRACKET, clamp LH	1	to 41121-98502-01J
2-3	41121-98502-01J	BRACKET, clamp LH	1	
3	41210-98400	SCREW, clamp	2	
4	41213-99001	PLATE, clamp	2	
5	09380-07001	RING, clamp plate	2	
6	41221-93001	KNOB, tilt stopper	1	
7	09205-03015	PIN, tilt stopper knob	1	
8	09200-12001	PIN, tilt stopper	1	
9	09300-12009	BUSHING	1	
10	41311-98500	PLATE, clamp bracket	1	
11	09125-06020	SCREW, clamp bracket	2	6x16
12	43321-96000	BUSHING, tilt friction	2	
13	09100-08144	BOLT, swivel shaft	1	8x145
14	09160-08015	WASHER, swivel shaft	2	8.5x16x1.6
15	09159-08018	NUT, swivel shaft	1	

FIG. 24

C - 14

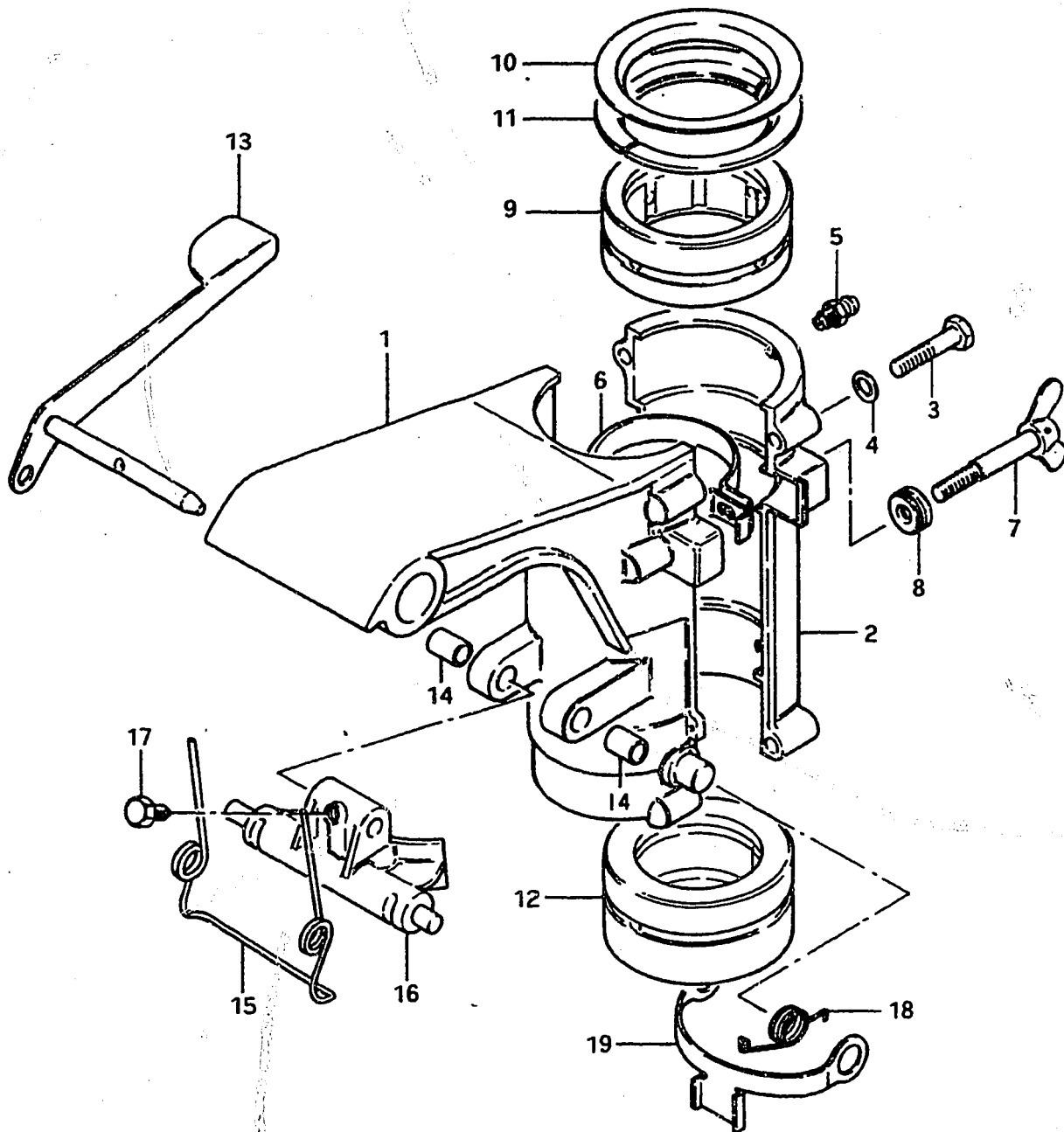

FIG. 24 SWIVEL BRACKET

Ref. No.	Part No.	Description	Q'ty	F	Remarks
1	43111-98300-01J	BRACKET, swivel	1		
2	43121-98300-01J	COVER, swivel bracket	1		
3	09100-06022	BOLT, swivel bracket	4		6x35
4	09160-06015	WASHER, swivel bracket	4		6.5x13x1
5	22511-99000	GREASE NIPPLE	2		
6-1	43411-98300	ADJUSTER, steering	1		to 43411-98301
6-2	43411-98301	ADJUSTER, steering	1		
7	09119-06044	BOLT, steering adjuster	1		
8	09308-08011	BUSHING, steering adjuster	1		
9-1	43721-98502	BUSHING, steering upper	1		to 43721-98503
9-2	43721-98503	BUSHING, steering upper	1		
10	43712-98500	PLATE, upper bushing	1		
11	43713-98500	PIECE, steering bushing	2		
12-1	43721-98300	BUSHING, steering lower	1		to 43721-98301
12-2	43721-98301	BUSHING, steering lower	1		
13-1	45110-98500	LEVER, rack	1		to 45110-98501
13-2	45110-98501	LEVER, rack	1		
14	09300-08005	BUSHING, rack lever	2		
15-1	45211-98500	SPRING, rack lever	1		to 45211-98502
15-2	45211-98502	SPRING, rack lever	1		
16-1	45411-98500-01J	BLOCK, thrust	1		
16-2	45411-98501-01J	BLOCK, thrust	1		
17	09139-05003	SCREW, rack lever	1		5x8
18	45212-98300	SPRING, reverse lock arm	1		
19-1	45231-98300-01J	ARM, reverse lock arm	1		to 45231-98990-01J
19-2	45231-98990-01J	ARM, reverse lock arm	1		to 45231-98301-01J
19-3	45231-98301-01J	ARM, reverse lock arm	1		

FIG. 25

C - 15

FIG. 25 DRIVE SHAFT HOUSING

Ref. No.	Part No.	Description	Q'ty	F	Remarks
1-1	52110-98310-01J	HOUSING, drive shaft	1		S type
1-2	52110-98320-01J	HOUSING, drive shaft	1		L type
2	09205-05001	DOWEL PIN, clutch lever	1		
3	52113-98300	GASKET, drive shaft housing	1		
4	09100-08112	BOLT, drive shaft housing	4		8x30
5	09108-08036	STUD BOLT, drive shaft housing	2		
6	09162-08003	LOCK WASHER	6		
7	09140-08003	NUT	2		
8	52115-98300	CAP, clutch adjusting hole	1		
9-1	09248-10003	PLUG, flushing	1		
9-2	09248-10004	PLUG, flushing	1		from 09248-10003
10	09168-10004	GASKET, flushing plug	1		to 09168-10022
11	09305-10007	BUSHING, drive shaft	1		

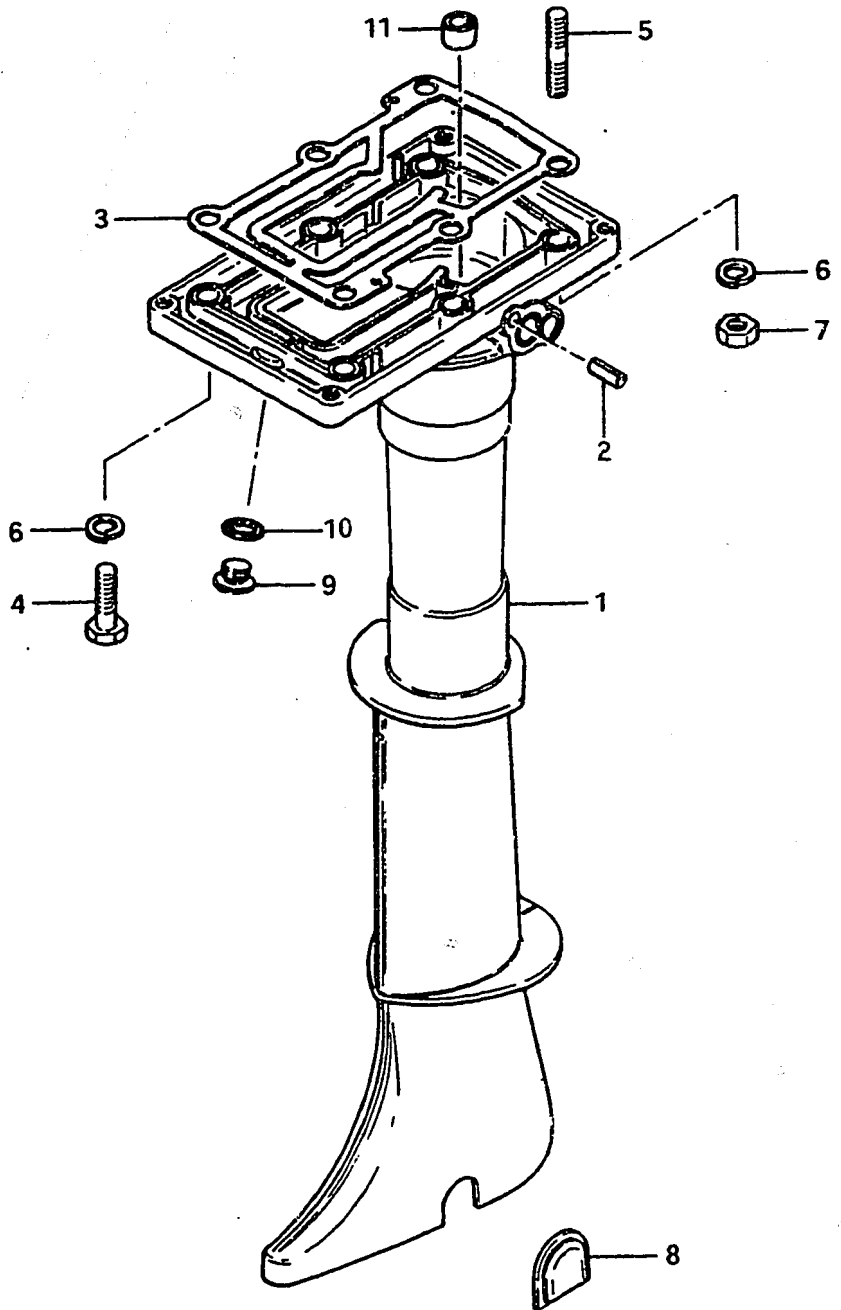

FIG. 26

D - 2

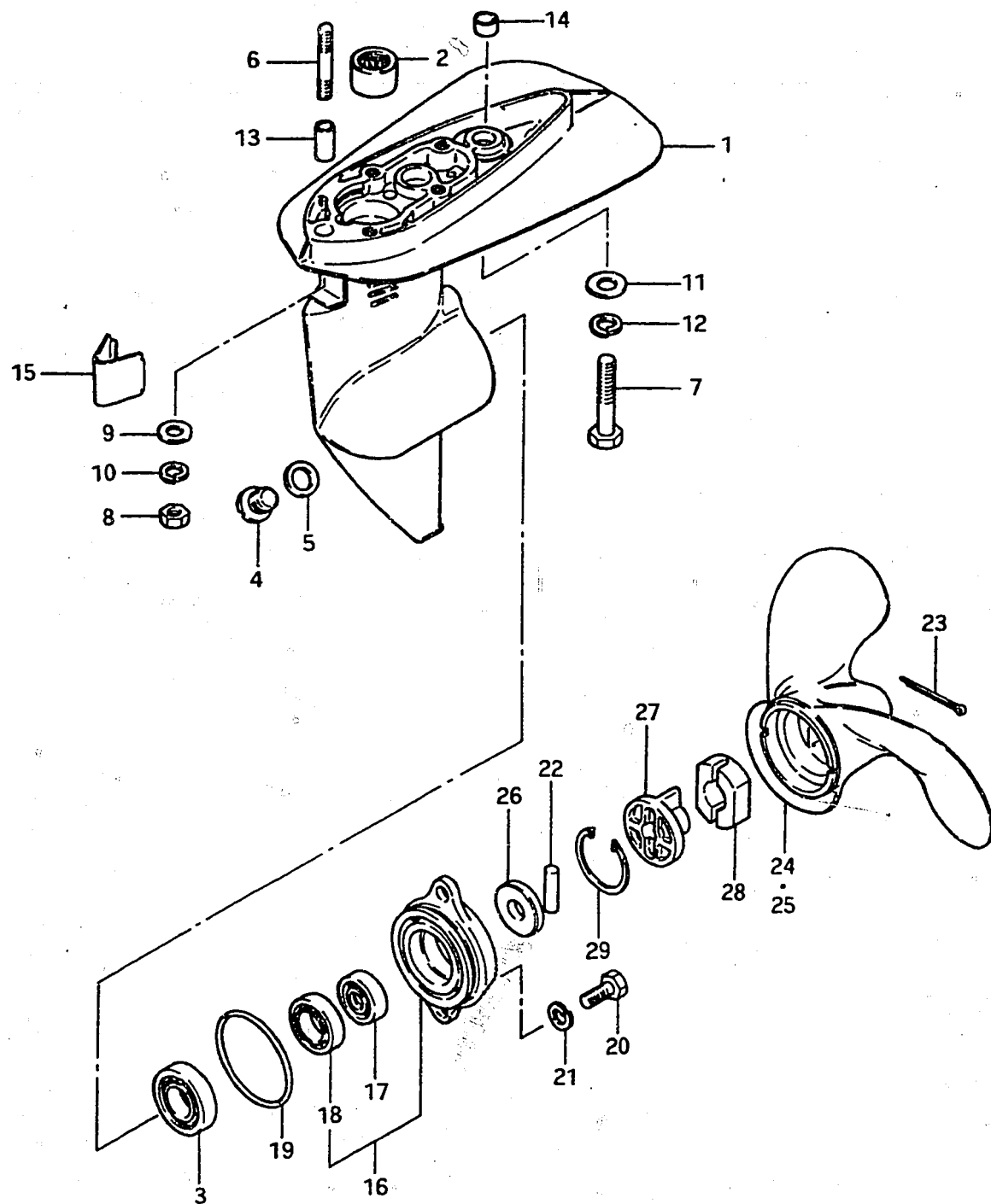
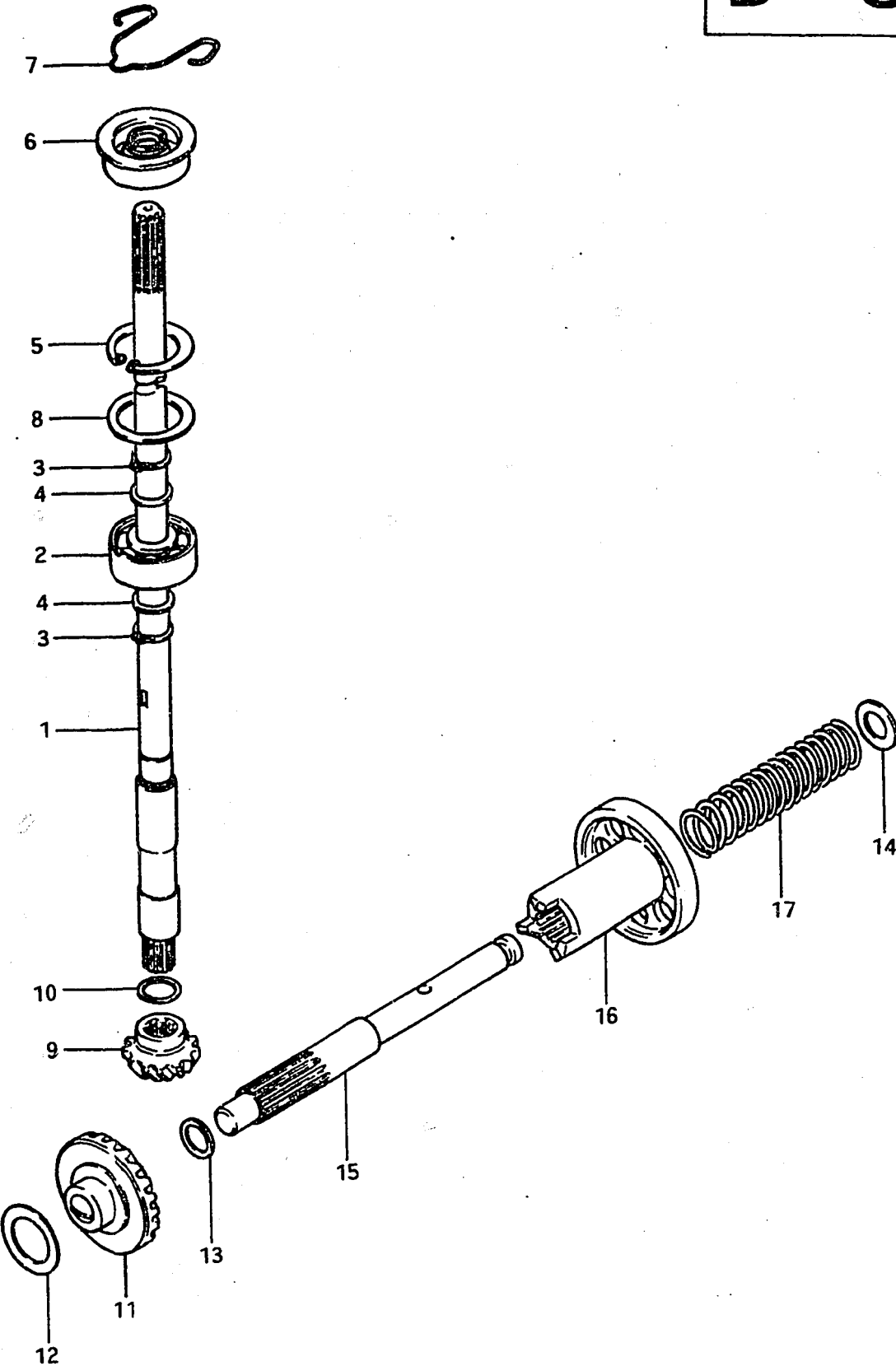

FIG. 26 GEAR CASE

Ref. No.	Part No.	Description	Q'ty	Remarks
1	55110-98300-01J	CASE SET, gear	1	from 55100-98830-01J
2	09263-14010	·BEARING, pinion	1	14x22x16
3	09262-17019	·BEARING, gear	1	17x35x8
4	09248-10003	PLUG, drain	1	
5	09168-10004	GASKET, drain plug	1	to 09168-10022
6	09108-06005	STUD BOLT, gear case	1	
7	09100-08112	BOLT, gear case	1	8x30
8	09140-06004	NUT	1	
9	09160-06015	WASHER	1	6.5x13x1
10	09162-06001	LOCK WASHER	1	
11	09160-08015	WASHER	1	8.5x16x1.6
12	09162-08003	LOCK WASHER	1	
13	09206-09003	PIN	1	
14	09206-11006	PIN	1	
15	53131-98400-01J	COVER, gear case bolt	1	
16	56110-98300-01J	HOUSING SET, bearing	1	from 56100-98810-01J to 56110-98301-01J
17	09289-10003	·OIL SEAL, bearing housing	1	10x26x8
18	08113-62000	·BEARING, propeller shaft	1	
19	09280-50003	O RING, bearing housing	1	
20	09100-06020	BOLT, bearing housing	2	6x20
21	09162-06001	LOCK WASHER	2	
22	09202-04002	SHEAR PIN	1	
23	09204-02001	COTTER PIN	1	
24-1	58111-98301-01T	PROPELLER (B600) (STD)	1	3x190x150 from 58111-98300-01T
24-2	58111-98302-01T	PROPELLER (B600) (STD)	1	3x190x150 from 58111-98301-01T
25	58111-98311-01T	PROPELLER (B510)	1	3x188x135 from 58111-98310-01T
26	09305-10006	BUSHING	1	
27	58121-98300	BUSHING, propeller	1	
28	58122-98300	RUBBER, propeller bushing	1	
29	09381-36002	CIRCLIP	1	

FIG. 27



D - 3

FIG. 27 TRANSMISSION

Ref. No.	Part No.	Description	Q'ty	F	Remarks
1-1	57110-98310	SHAFT, drive (L:649)	1		S type
1-2	57110-98320	SHAFT, drive (L:776)	1		L type
2	08113-62000	BEARING, drive shaft	1		
3	08331-31109	CIRCLIP	2		
4	08211-10161	THRUST WASHER	2		
5	08331-41309	CIRCLIP, drive shaft bearing	1		
6	09289-10004	OIL SEAL, drive shaft	1		10x35x9
7	09381-36001	SNAP RING, oil seal	1		to 09387-39001
8-1	08221-22303	SHIM	AR(0~2)		T:0.1
8-2	08221-22304	SHIM	AR(0~2)		T:0.2
8-3	08221-22305	SHIM	AR(0~2)		T:0.5
9	57311-98300	PINION	1		
10-1	08221-10143	SHIM, pinion	AR(0~2)		T:0.1
10-2	08221-10144	SHIM, pinion	AR(0~2)		T:0.2
10-3	08221-10145	SHIM, pinion	AR(0~2)		T:0.5
11-1	57511-98300	GEAR	1		to 57510-98300
11-2	57510-98300	GEAR	1		
12-1	08221-17263	SHIM, gear	AR(0~2)		T:0.1
12-2	08221-17264	SHIM, gear	AR(0~2)		T:0.2
12-3	08221-17265	SHIM, gear	AR(0~2)		T:0.5
13-1	08211-10141	THRUST WASHER, gear	AR(0~2)		T:1.0
13-2	08211-10142	THRUST WASHER, gear	AR(0~2)		T:1.5
14	08211-10181	THRUST WASHER, propeller shaft	AR(0~2)		
15	57611-98300	SHAFT, propeller	1		
16	57621-98300	SHIFTER, clutch dog	1		
17	09440-17003	SPRING, return	1		

FIG. 28

D - 4

16

FIG. 28 HANDLE

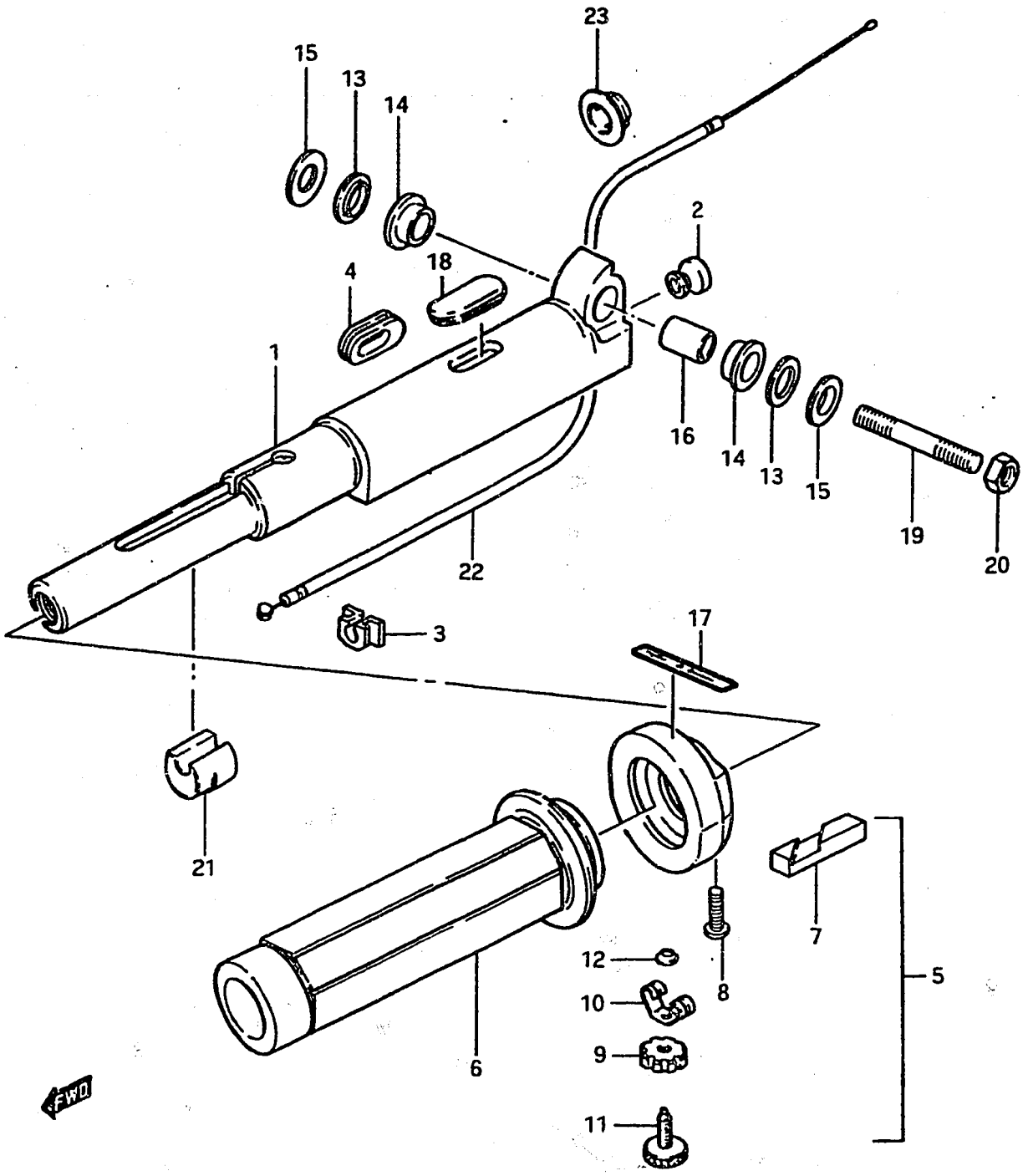

Ref. No.	Part No.	Description	Q'ty	F	Remarks
1	63111-96100-01J	HANDLE, tiller	1		
2	09321-07001	CUSHION, handle	1		
3	63112-93103	GROMMET, stop switch cord	1		
4	63113-96000	GROMMET, cable support	1		
5-1	63200-93102	GRIP ASSY, throttle	1		to 63200-93103
5-2	63200-93103	GRIP ASSY, throttle	1		
6-1	63210-93101	•GRIP, throttle	1		to 63210-93102
6-2	63210-93102	•GRIP, throttle	1		
7	63214-93100	•PIECE, sliding	1		
8	63218-93100	•SCREW	2		
9	63242-93101	•LOCK NUT	1		
10	63243-93101	•SPRING	1		
11	63244-93101	•SCREW	1		
12	63245-93100	•PUSH NUT	1		
13	63321-99000	SEAT, handle rubber	2		
14	09305-12007	BUSHING, handle cushion	2		
15	09160-10041	WASHER, handle pivot	2		10.3x25x1.5
16	09303-10001	BUSHING, handle pivot	1		
17	63215-93101	MARK, handle grip	1		
18	09250-08006	CAP, tiller handle	1		
19	09108-10026	STUD BOLT, handle pivot	1		
20	09140-10017	NUT, handle	1		
21	63331-93101	FRICITION, handle	1		
22	63610-98301	CABLE ASSY, throttle	1		
23	09308-12008	GROMMET, throttle cable	1		

FIG. 29

D - 5

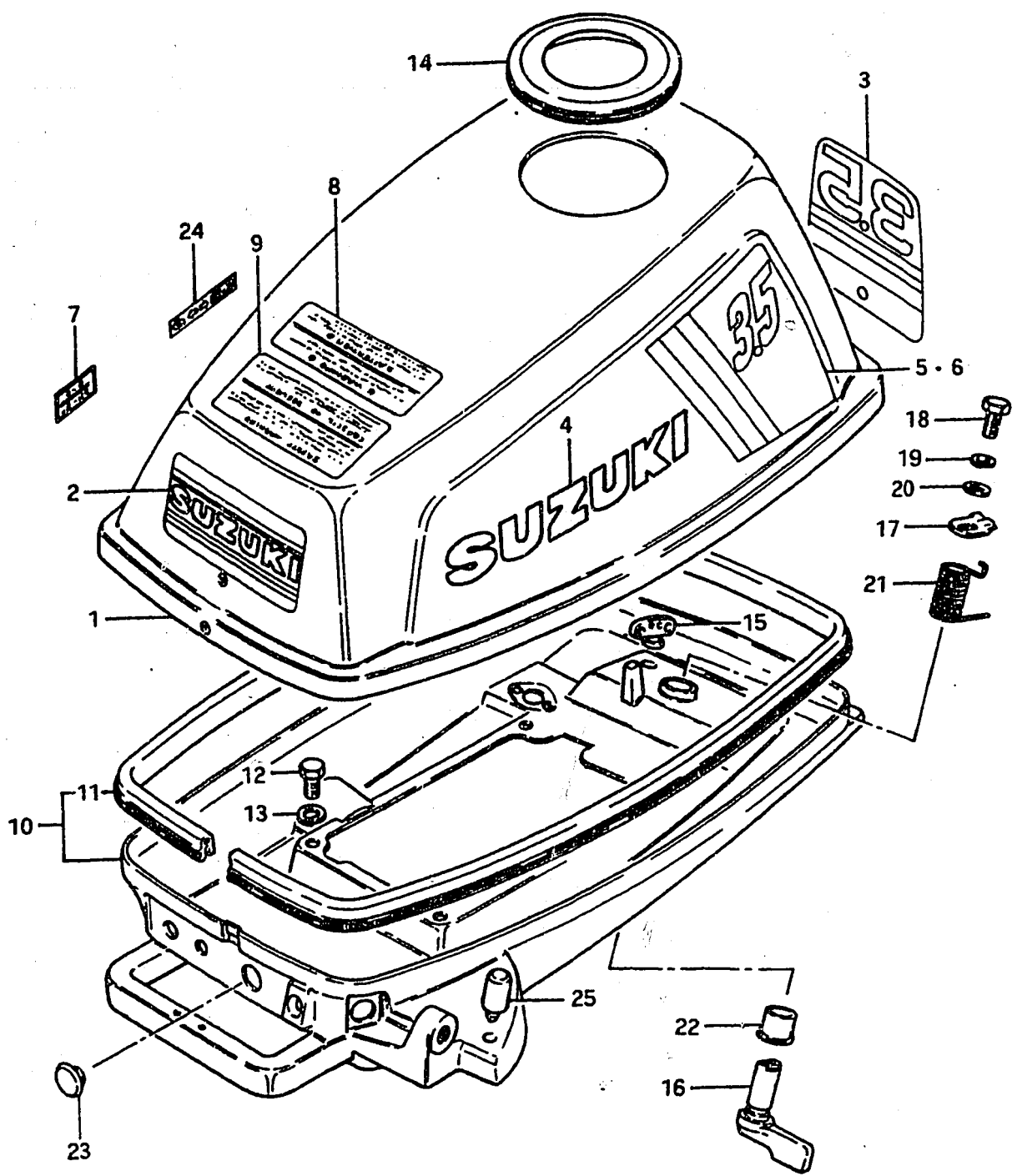

FIG. 29 ENGINE COVER

Ref. No.	Part No.	Description	Q'ty	Remarks
1	61400-98851-01T	COVER SET, engine	1	from 61400-98850-01T
2	61422-98501	·MARK, emblem front "SUZUKI"	2	
3	61435-98300	·MARK, emblem rear "3.5"	1	
4-1	61441-98401	·EMBLEM, engine cover "SUZUKI"	2	
4-2	61441-98410	·EMBLEM, engine cover "SUZUKI"	2	from 61441-98401
5	61443-98300	·DECAL, engine cover RH "3.5"	1	
6	61453-98300	·DECAL, engine cover LH "3.5"	1	
7	21131-98310	·MARK, clutch shifting	1	
8	61457-98500	MARK, warning	1	
9	61458-98500	MARK, safety warning	1	
10-1	61110-98300-01J	COVER, engine lower to (61110-98301-01J)+(61521-98400)	1	to 61110-98302-01J
10-2	61110-98301-01J	COVER, engine lower	1	
10-3	61110-98302-01J	COVER, engine lower	1	
11	61112-98300	·RUBBER, lower cover	1	
12	09100-06019	BOLT, lower cover	4	6x16
13	09162-06001	LOCK WASHER	4	
14	61433-98300	CAP, engine cover	1	
15-1	61521-96000	HOLDER, shear pin	1	D:11φ
15-2	61521-98400	HOLDER, shear pin	1	D:15φ
16	61633-98300-01J	LEVER, hook	1	
17	61631-98300	HOOK, lower cover	1	
18	01107-06168	BOLT, hook lever	1	
19	08321-21068	LOCK WASHER	1	
20	08322-21068	WASHER	1	
21	09448-16018	SPRING, hook lever	1	
22	09306-13002	BUSHING, hook lever	1	
23	37101-93301	CAP, lower cover	1	
24	61211-98300	MARK, fuel cock	1	
25-1	09321-06020	CUSHION, handle tiller	1	to 09321-06021
25-2	09321-06021	CUSHION, handle tiller	1	

FIG. 30

D - 6

FIG. 30 FUEL TANK

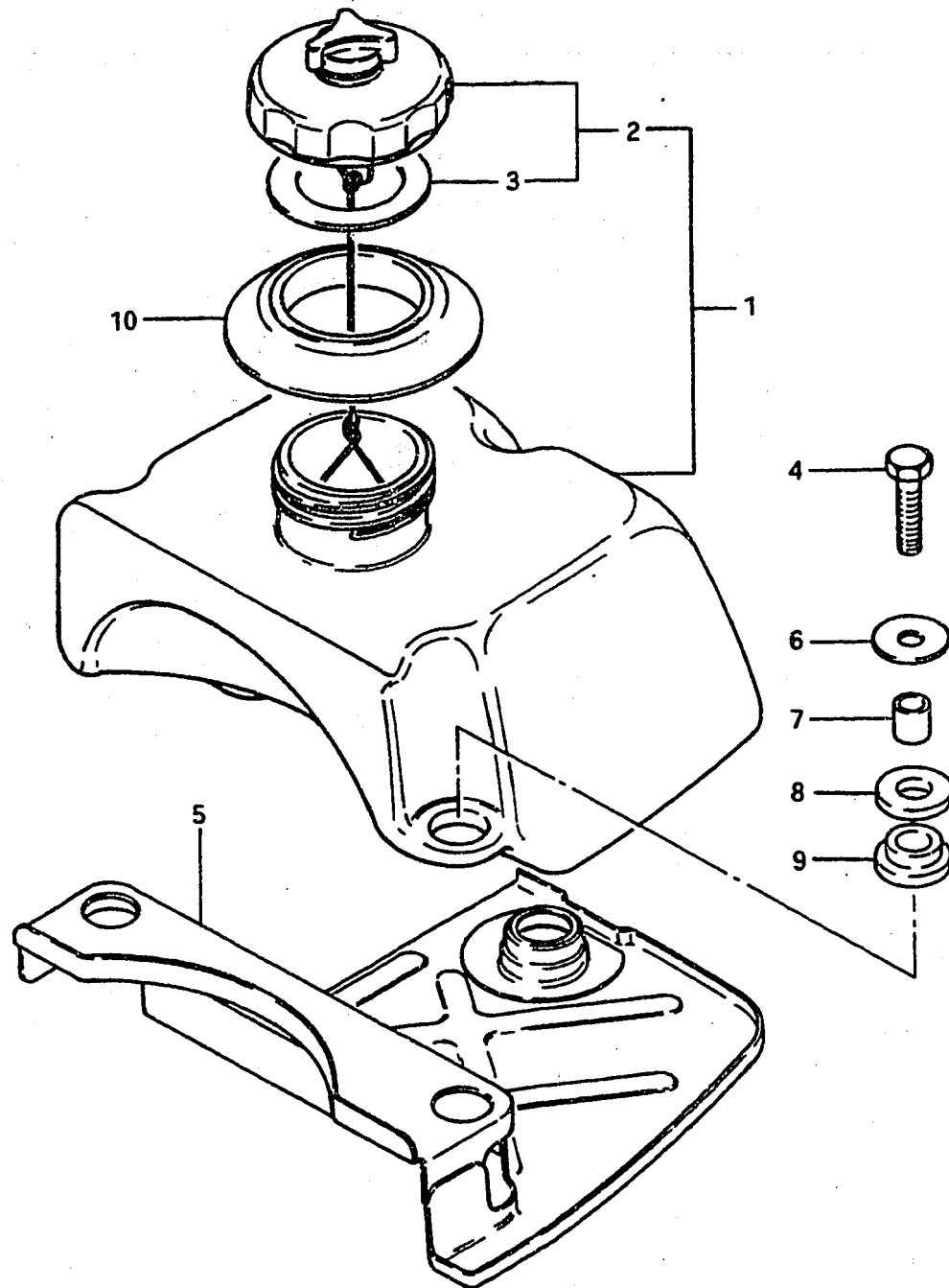

Ref. No.	Part No.	Description	Q'ty	Remarks
			F	
1-1	65100-98860	TANK SET, fuel	1	to 65100-98861
1-2	65100-98861	TANK SET, fuel	1	
2	65510-98402	•CAP ASSY, fuel tank	1	
3	09168-32001	••GASKET, fuel tank cap	1	
4	01107-06308	BOLT	3	
5	65120-98300	PLATE, fuel tank	1	
6	09160-06054	WASHER, fuel tank	3	
7	09180-06006	SPACER, fuel tank	3	
8	09320-10016	CUSHION, fuel tank upper	3	
9	09320-09013	CUSHION, fuel tank lower	3	
10	65281-98300	GROMMET, fuel tank	1	

FIG.1

K - 3

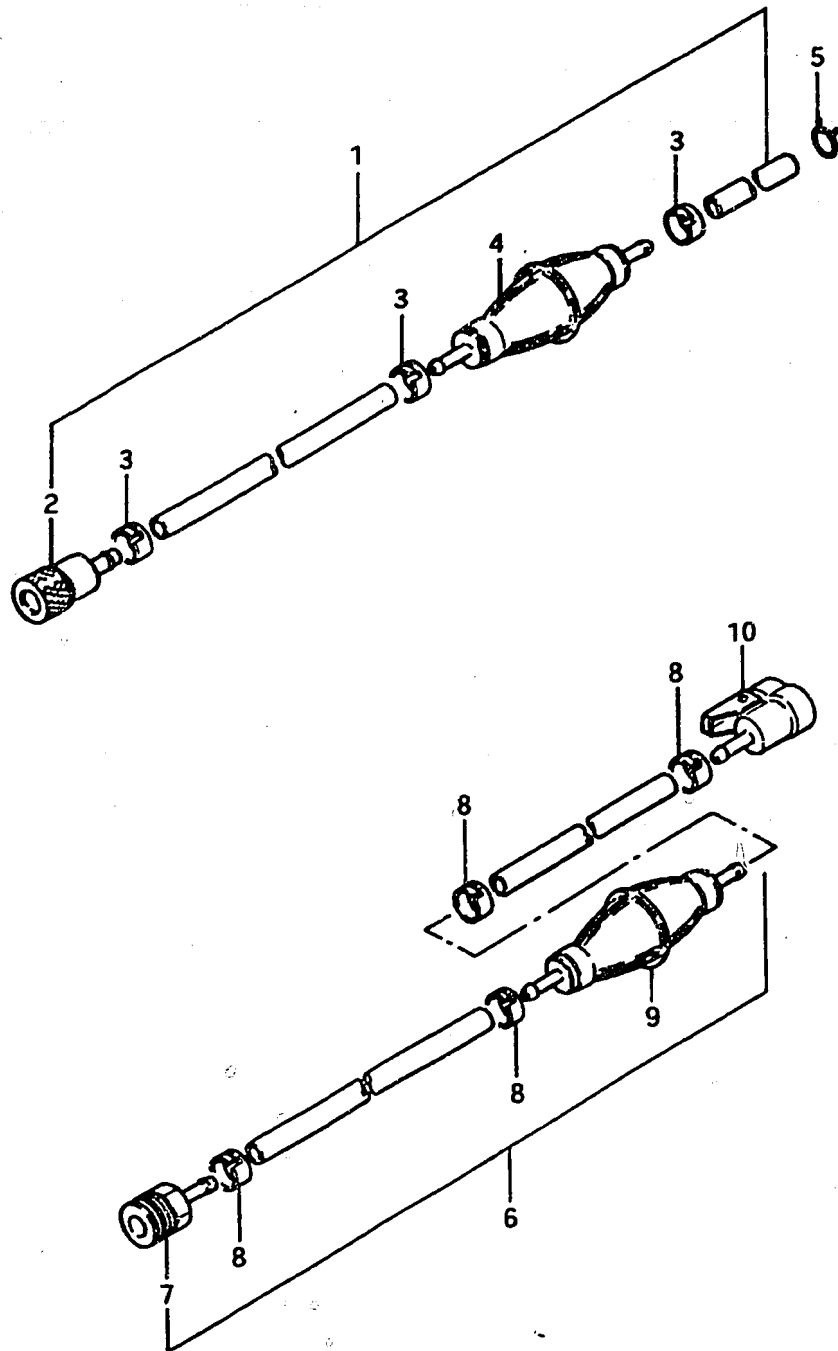

1

FIG.1 FUEL HOSE

Ref. No.	Part No.	Description	Q'ty		Remarks
			D	F	
(DT5DE1, DT3.5FE16, DT5FE1, DT7.5FE1, DT9FE1)					
1-1	65700-98500	HOSE ASSY, fuel	1	1	to 65700-98501
1-2	65700-98501	HOSE ASSY, fuel	-	1	to 65700-98502
1-3	65700-98502	HOSE ASSY, fuel	-	1	to 65700-98503
1-4	65700-98503	HOSE ASSY, fuel	-	1	
1-5	65700-98992	HOSE ASSY, fuel	-	1	from 65700-98503
2-1	65750-98500	•SOCKET	1	1	to 65750-98501
2-2	65750-98501	•SOCKET	-	1	to 65750-98502
2-3	65750-98502	•SOCKET	-	1	
2-4	65750-98990	•SOCKET	-	1	from 65750-98502 to 65750-98505
3	09401-13402	•CLIP	3	3	
4-1	65770-99700	•PUMP, squeeze	1	1	to 65770-99701
4-2	65770-99701	•PUMP, squeeze	-	1	to 65770-99702
4-3	65770-99702	•PUMP, swueeze	-	1	
5	09401-11402	CLIP	1	1	
6-1	65700-98510	HOSE ASSY, fuel	1	1	to 65700-98511
6-2	65700-98511	HOSE ASSY, fuel	-	1	to 65700-98512
6-3	65700-98512	HOSE ASSY, fuel	-	1	to 65700-98513
6-4	65700-98513	HOSE ASSY, fuel	-	1	
6-5	65700-98990	HOSE ASSY, fuel	-	1	from 65700-98513 to 65700-95991
7-1	65750-98500	•SOCKET	1	1	to 65750-98501
7-2	65750-98501	•SOCKET	-	1	to 65750-98502
7-3	65750-98502	•SOCKET	-	1	E13
7-4	65750-98990	•SOCKET	-	1	from 65750-98502 to 65750-98505
8	09401-13402	•CLIP	4	4	
9-1	65770-99700	•PUMP, squeeze	1	1	to 65770-99701
9-2	65770-99701	•PUMP, squeeze	-	1	to 65770-99701
9-3	65770-99702	•PUMP, squeeze	-	1	
10	65750-99700	•SOCKET	1	1	

FIG.7

K - 9

7

FIG.7 FUEL TANK (NEW TYPE)

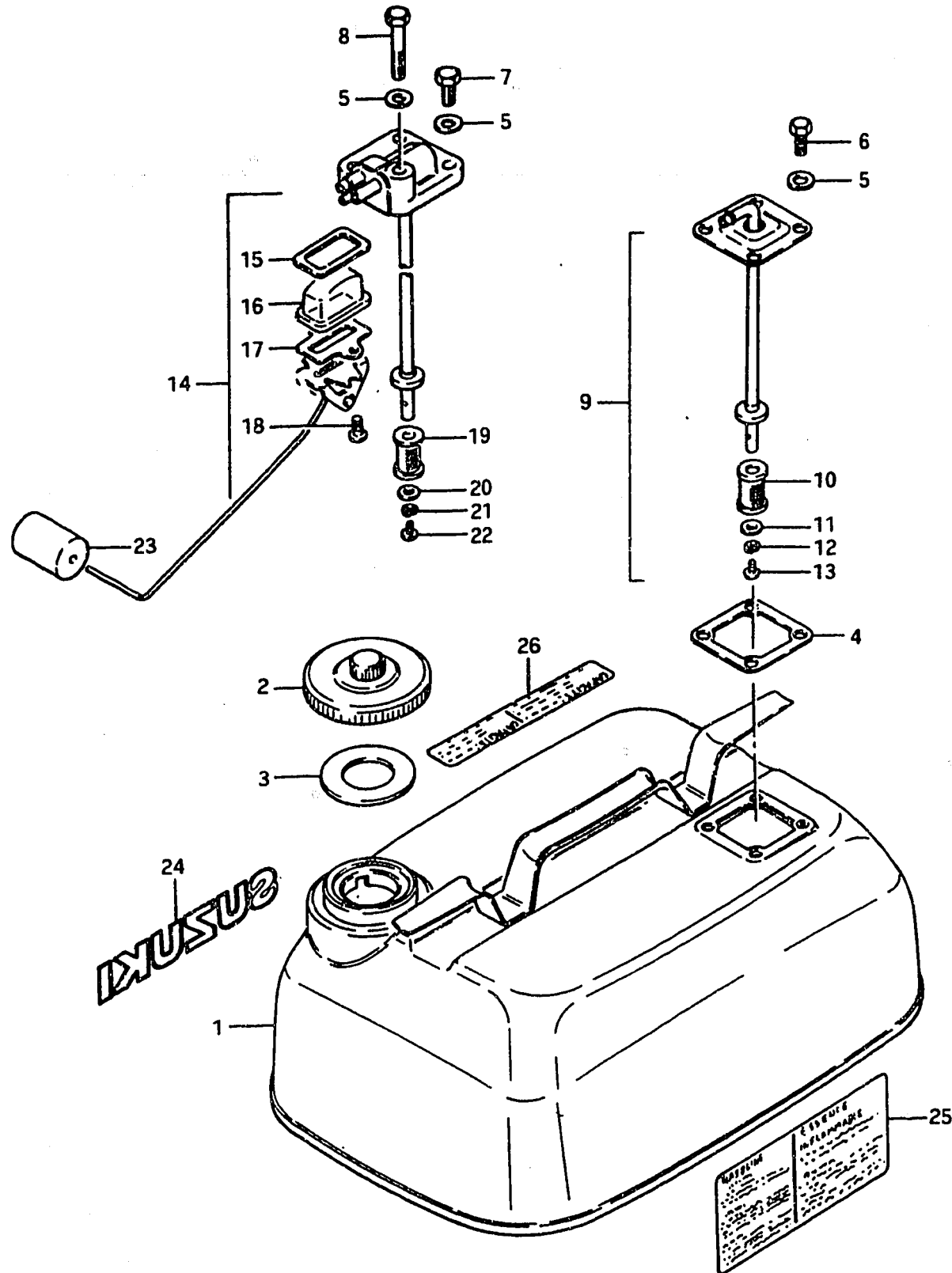

Ref. No.	Part No.	Description	Q'ty	Remarks
		(DT3.5FE16, DT5FE1 OPT, DT7.5FE1, DT9FE1)		
1	65800-98840	TANK SET (15ℓ) (4 U.S.GAL.) (3.3 IMP.GAL) to (65800-98841)+(61441-98500)+(65316-93301)	1	
2-1	65510-98500	•CAP ASSY	1	to 65510-98501
2-2	65510-98501	•CAP ASSY	1	to 65510-98502
2-3	65510-98502	•CAP ASSY	1	to 65510-98503
3-1	65561-98500	•GASKET	1	to 65561-98501
3-2	65561-98501	•GASKET	1	
4	65871-93001	•GASKET, fuel gauge	1	
5	08322-21068	•WASHER	4	
6	01107-06168	•BOLT	4	
7	01107-06168	•BOLT	3	DT5FE13,DT7.5FE13
8	01107-06408	•BOLT	1	
9	65880-98500	OUTLET, separate tank	1	
10	65830-93301	•FILTER	1	
11	08322-21058	•WASHER	1	
12	08321-21058	•LOCK WASHER	1	
13	02112-05088	•SCREW	1	
14-1	65850-98500	GAUGE ASSY, fuel	1	to 65850-98501
14-2	65850-98501	GAUGE ASSY, fuel	1	
15-1	65854-93000	•GASKET	1	to 65854-93001
15-2	65854-93001	•GASKET	1	
16	65853-93001	•STRAINER	1	
17	65862-93000	•GASKET, arm holder	1	DT5FE13,DT7.5FE13
18	02112-04108	•SCREW	2	
19	65830-93301	•FILTER	1	
20	08322-21058	•WASHER	1	
21	08321-21058	•LOCK WASHER	1	
22	02112-05088	•SCREW	1	
23	65864-93000	•FLOAT	1	
24	61441-98500	EMBLEM, side	1	
25-1	65316-93300	MARK, fuel caution	1	to 65316-93301
25-2	65316-93301	MARK, fuel caution	1	to 65316-93302
25-3	65316-93302	MARK, fuel caution	1	to 65316-93303
26	65317-98500	MARK, fuel capacity	1	

FIG. 9

K - 11

FIG.9 OPT : GASKET / TOOL SET

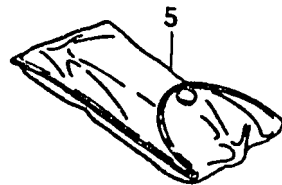
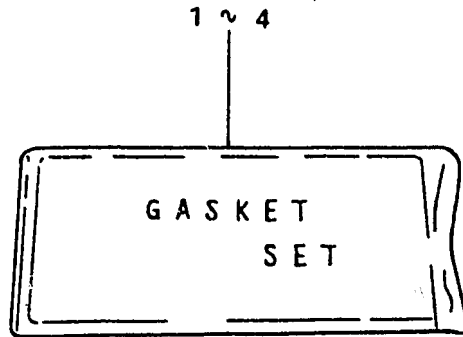

Ref. No.	Part No.	Description	Q'ty	Remarks
1	11400-98840	GASKET SET (ENGINE)	1	DT3.5
2	11400-98820	GASKET SET (ENGINE)	1	DT4,DT4.5
3-1	11400-98830	GASKET SET (ENGINE)	1	DT5D, to 11400-98831
3-2	11400-98832	GASKET SET (ENGINE)	1	DT5F to 11400-98833
3-3	11400-98833	GASKET SET (ENGINE)	1	
4	11400-96820	GASKET SET (ENGINE)	1	DT7.5,DT9 to 11400-96821
5-1	09800-00128	TOOL SET (DT3.5~DT9)	1	to 09800-00805
5-2	09800-00178	TOOL SET (DT2)	1	to 09800-00805

FIG.10

K - 12

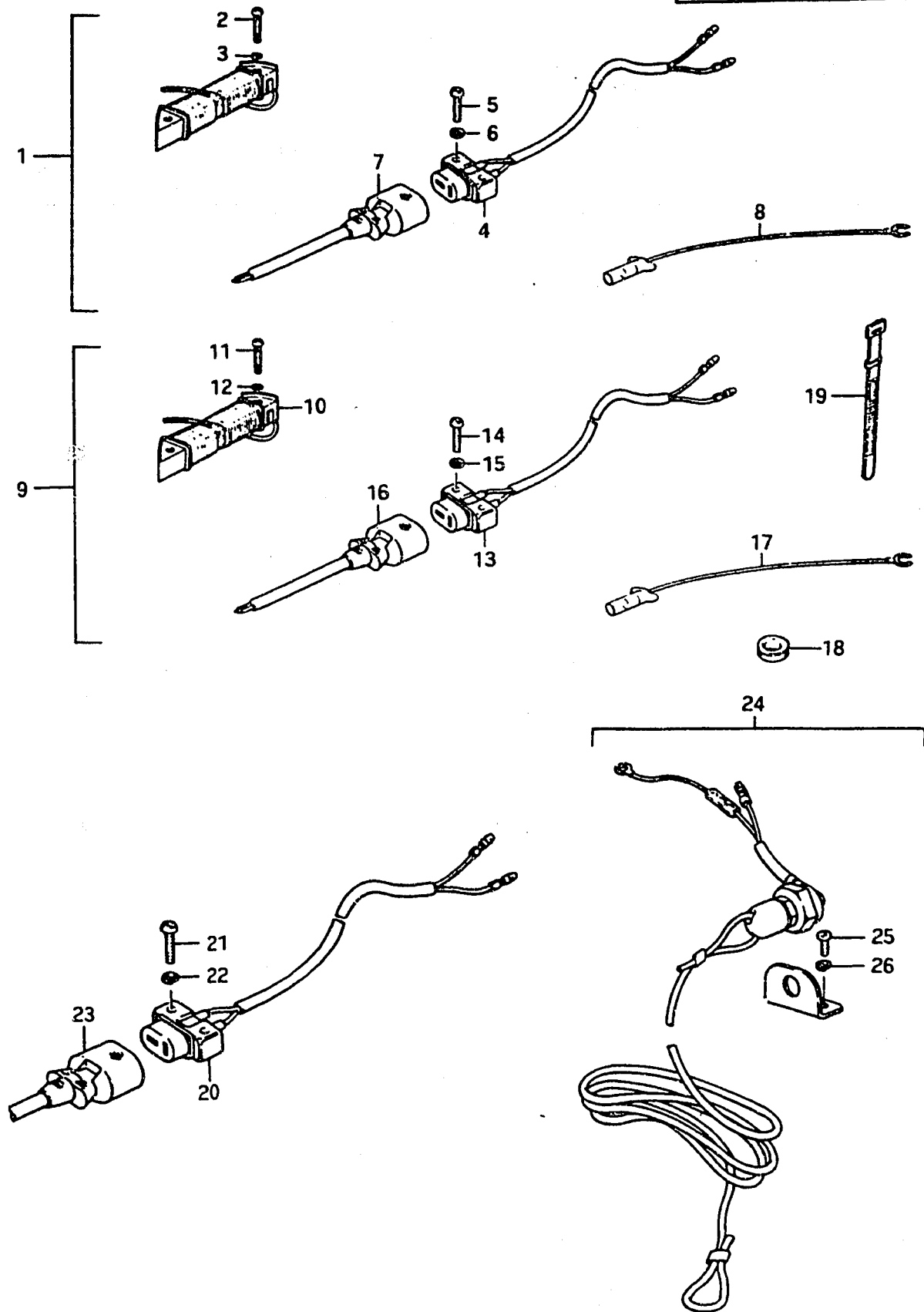
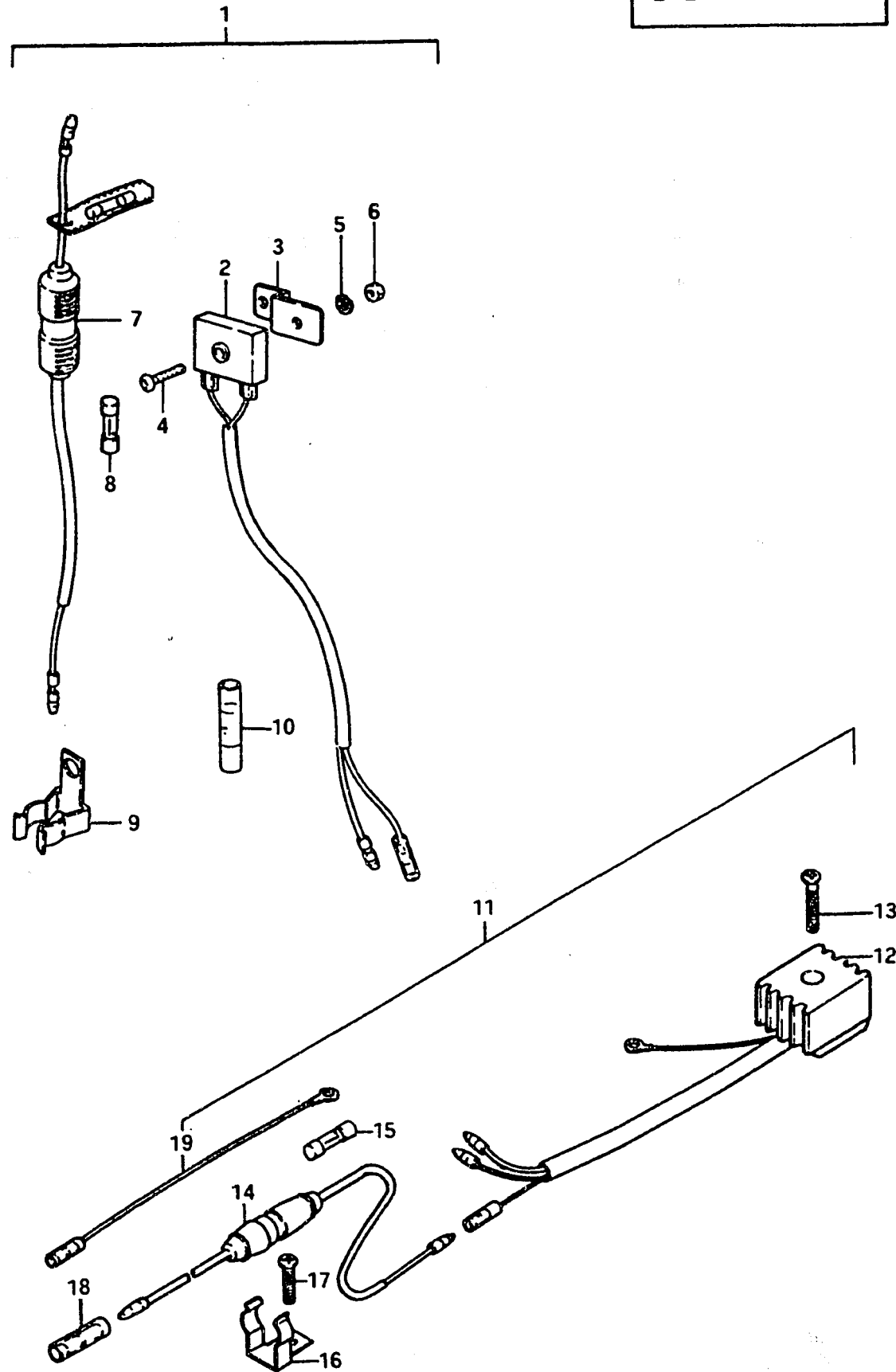

FIG.10 OPT : LIGHTING COIL, EMERGENCY SWITCH

Ref. No.	Part No.	Description	Q'ty	Remarks
1	32200-98821	COIL SET, lighting to (32200-98300)+(39600-98300)	1	DT2 DT3.5 DT4,DT4.5
2	02112-05258	•SCREW	2	
3	08321-21058	•LOCK WASHER	2	
4	39601-96711	•SOCKET ASSY	1	
5	02112-04208	•SCREW	2	
6	08322-21048	•WASHER	2	
7	39602-99711	•PLUG ASSY, lighting	1	
8	36898-93300	•LEAD WIRE, earth	1	
9	32200-98832	COIL SET, lighting	1	DT5
10	32120-98520	•COIL, lighting	1	
11	02112-06258	•SCREW	2	
12	08321-21068	•LOCK WASHER	2	
13	39601-96711	•SOCKET ASSY	1	
14	02112-04258	•SCREW	2	
15	08322-21048	•WASHER	2	
16	39602-99711	•PLUG, lighting	1	
17	36898-93300	•LEAD WIRE, earth	1	
18	09308-10002	•GROMMET, lead wire	1	
19	09407-12402	•CLAMP, lead wire	1	
20	39601-96711	•SOCKET ASSY	1	DT7.5,DT9
21	02112-04208	•SCREW	2	
22	08322-21048	•WASHER	2	
23	39602-99711	•PLUG, lighting	1	DT2~DT9
24-1	37800-93812	SWITCH SET, emergency from 37800-93811	1	
24-2	37800-93813	SWITCH SET, emergency from 37800-93812	1	
25	09125-04011	•SCREW	2	DT2~DT9
26	09162-04002	•LOCK WASHER	2	

FIG. 11

K - 13



11

FIG. 11 OPT : RECTIFIRE

Ref. No.	Part No.	Description	Q'ty	Remarks
1-1	32800-98810	RECTIFIRE SET	1	to 32800-98811
1-2	32800-98811	RECTIFIRE SET	1	
2	32800-95220	•RECTIFIRE ASSY	1	DT3.5 DT5
3	32890-98000	•STAY, rectifire	1	
4	02112-05208	•SCREW	1	
5	08321-21058	•LOCK WASHER	1	
6	08310-11058	•NUT	1	
7	36740-95252	•CASE ASSY, fuse from 36740-95251	1	
8	09481-20001	••FUSE (20A)	1	
9	36791-95200	•HOLDER, fuse case	1	
10	37132-93700	•CONNECTOR	1	
11-1	32800-96810	RECTIFIRE SET	1	
11-2	32800-96811	RECTIFIRE SET	1	
12	32800-95720	•RECTIFIRE ASSY	1	DT7.5, DT9
13	02112-05258	•SCREW	1	
14	36740-95252	•CASE ASSY, fuse from 36740-95251	1	
15	09481-20001	••FUSE (20A)	1	
16	36791-95200	•HOLDER, fuse case	1	
17	09125-06020	•SCREW, fuse case	1	
18	37132-93700	•CONNECTOR	1	
19	36898-93300	•LEAD WIRE, earth	1	

DT2~DT9

DT2~DT9

FIG.14 OPTIONAL

FIG.14

L - 2

Ref. No.	Part No.	Description	Qty	Remarks
1	99000-31030	GASKET, liquid	1	for crankcase,100g
2	99000-31050	GASKET, liquid	1	for gear case,100g
3	99000-32040	CEMENT, thread lock	1	200g
4-1	99000-25160	GREASE, water resistant	1	250g
4-2	99000-25170	GREASE, water resistant	1	50g
5	99000-22540	GEAR OIL, outboard motor	1	400cc
6	99000-25010	SUZUKI SUPER GREASE A	1	450g,for crank oil seal
7	99000-32030	SUZUKI LOCK SUPER	1	50g (1303B)
8	09914-39911	HANGER, engine	1	
9-1	99000-10105-01T	PAINT (500g)	1	
9-2	99000-10205-01J	PAINT (500g)	1	
10-1	99000-10109-01T	PAINT (90g)	1	
10-2	99000-10209-01J	PAINT (90g)	1	
11-1	99000-21460	CCI OIL (1ℓx24,Mitsubishi)	1	
11-2	99000-21145	CCI OIL (1ℓx24,Shell)	1	
11-3	99000-21021	CCI OIL (4ℓx6)	1	
11-4	99000-21150	CCI OIL (200ℓ)	1	
11-5	99000-21250	CCI SUPER OIL (1ℓx24)	1	
11-6	99000-21260	CCI SUPER OIL (4ℓx6)	1	

